

Self-consumption or Grid independence

with the Victron Energy Storage Hub

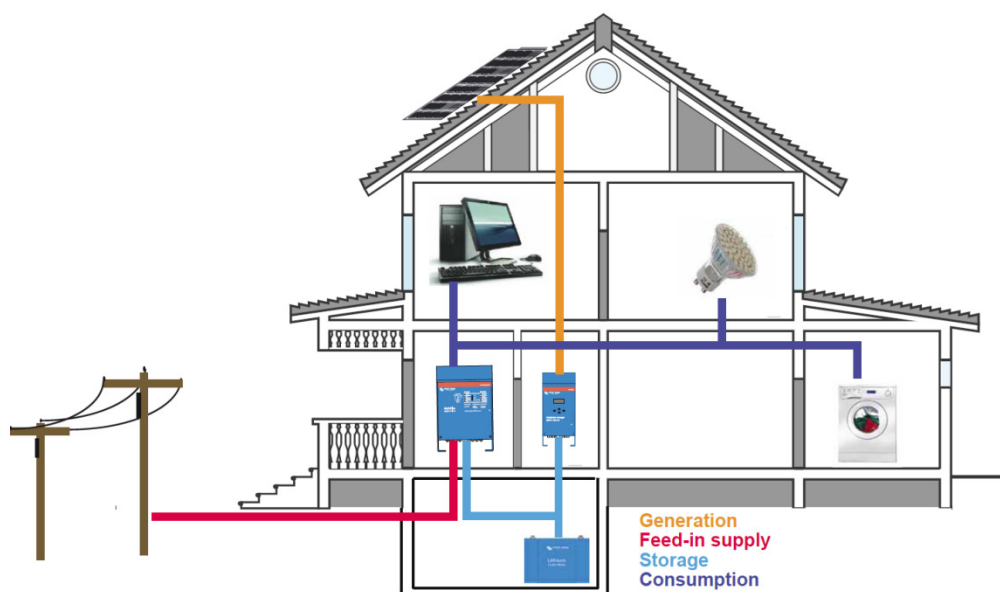

- 1. Introduction**
- 2. Three system alternatives**
 - 2.1. VE Storage Hub-1**
 - 2.2. VE Storage Hub-2**
 - 2.3. VE Storage Hub-3**
- 3. Essential feature of the three system alternatives: GridAssist**
- 4. Short description of the main components of the VE Storage Hub**
 - 4.1. Battery: lead acid or Li-ion, part 1.**
 - 4.2. MultiPlus and Quattro inverter/chargers**
 - 4.3. BlueSolar MPPT solar charge controller**
 - 4.4. PV inverter**
- 5. Electric power consumption at home**
 - Base load (category 1 loads)**
 - Other plug-in appliances (category 2 loads)**
 - Non movable loads (category 3 loads)**
- 6. Efficiency of the Hub**
- 7. The Hub for the grid connected home**
 - 7.1. Powering the base load with Hub-1 and a Li-ion battery**
 - 7.2. Base load plus other plug-in appliances (category 2 and 3 loads) powered with Hub-1**
 - 7.3. Powering the base load with Hub-2 or -3**
 - 7.4. Base load plus other plug-in appliances powered with Hub-2 or -3**
 - 7.5. What about dark and rainy wintertime?**
- 8. The off grid Hub**
 - 8.1. Micro-CHP**
 - 8.2. Diesel engine powered generator**
- 9. Definition: the 100% PV array and the 100% battery**
- 10. Cost**
 - 10.1. Self-consumption: optimal storage capacity**
 - 10.2. Off-grid: optimal storage capacity**
 - 10.3. Battery: lead acid or Li-ion, part 2**
 - 10.4. The PV array**
 - 10.5. Examples: cost of the major components**

1. Introduction

Electrical power generated by the sun and/or wind, and actual power consumption never match. The result is feedback of power into the grid when excess power is generated, and power needed from the grid when power generation is insufficient.

As more solar and wind power comes on line, it becomes increasingly difficult, and expensive, to ensure stability of the grid.

Intermediate energy storage is therefore rapidly becoming an essential tool to keep power fluctuations on the grid within manageable limits.

Moreover, as feed-in tariffs are decreasing, the business case for a home energy storage system that increases self-consumption becomes more solid every day.

Intermediate energy storage increases self-consumption of harvested solar and/or wind power. The natural next step is 100% self consumption and independence from the grid.

The Victron Energy Storage Hub offers the solution, and several additional benefits

With tens of thousands of grid independent and grid interactive systems installed worldwide, we have the experience and the products to design the optimal system.

- **Battery**

The core of the Hub consists of the battery, which is charged in case of excess solar/wind power and discharged when consumption exceeds production.

Tubular plate OPzS and OPzV lead acid batteries have proven to perform very well in grid interactive as well as off grid systems.

Alternatively, a Li-ion battery will be the preferred solution when high charge/discharge efficiency, small size and low weight are important.

For more information see section 4.1 and 9.3.

- **Grid friendly**

The Hub can be used to reduce peak demand from the grid (by discharging the battery) as well as peak supply back to the grid (by recharging the battery).

For more information see section 9.1.

- **Ride through a power outage**

Energy stored in the battery can be used to provide power to essential equipment during a power outage.

- **Grid independence**

With sufficient battery capacity and, if needed, a micro-CHP or back-up genset, complete independence from the grid can be achieved.

- **Flexible**

We do not offer one Hub, but three alternative configurations, each of which can be tailored to specific requirements.

- **Field upgradable**

Additional solar/wind power and battery storage can be connected at a later stage.

2. Three system alternatives

2.1. VE Storage Hub-1

Hub-1 is the highest efficiency solution when most of the energy produced has to be stored in the battery prior to use.

It is also the simplest, most robust and lowest cost solution.

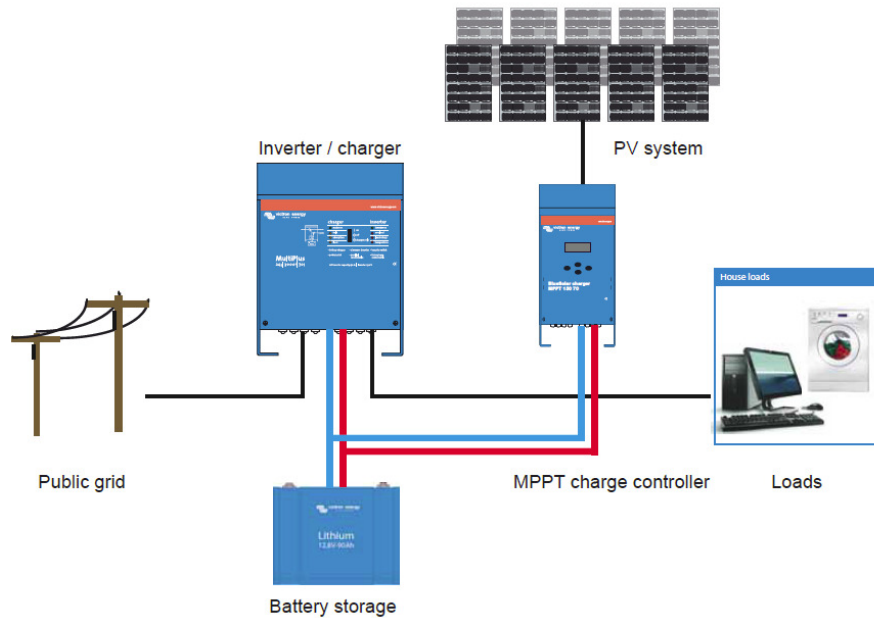

The BlueSolar MPPT charge controller uses solar power to charge the battery.

The stored energy is used by a MultiPlus or Quattro inverter/charger to supply AC power to the load and to feed excess power back into the grid.

In case of a utility power outage, the Hub will disconnect from the grid and continue to operate as a standalone system.

If power will be fed back into the grid an anti islanding device that complies to local regulations has to be added to the system.

Note: Hub-1 can be combined with Hub-2 or -3. One part of the solar array would then be connected to a charge controller and the remainder to a PV inverter.

2.2. VE Storage Hub-2

This is the most practical solution to add battery storage to an existing grid connected PV system.

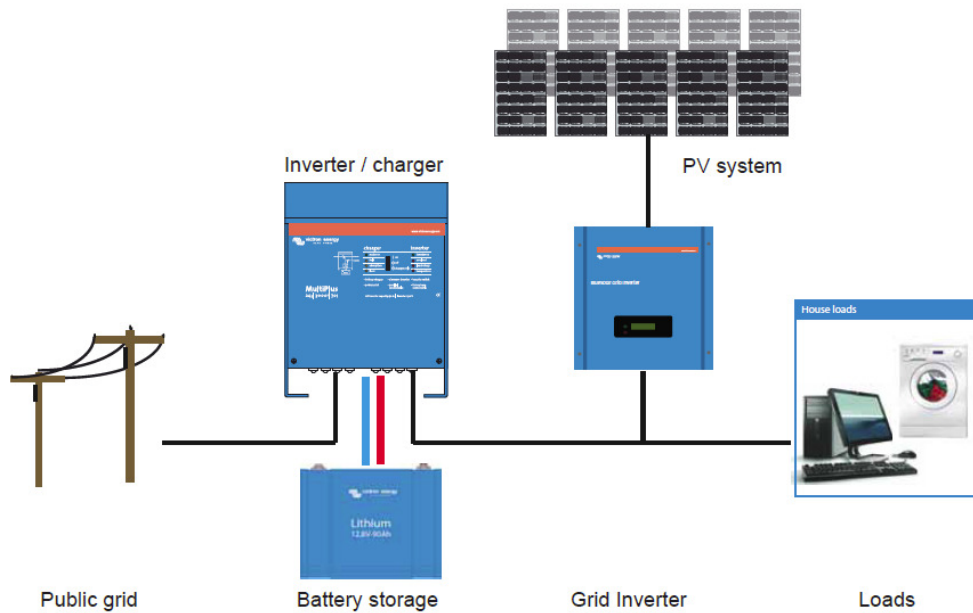

DC electrical power generated by the solar panels is converted to AC by a PV inverter connected to the AC **output** of an inverter/charger.

The AC input of the inverter/charger is connected to the grid.

If power will be fed back into the grid an anti islanding device may have to be added to the system, depending on local regulations.

Power from the PV inverter is supplied directly to the load.

In case of insufficient PV power, the inverter/charger will supply additional power from the battery, or from the grid.

In case of excess PV power the inverter/charger will use the excess power to recharge the battery, and/or to feed power back into the grid.

In case of a utility power outage, the Hub will disconnect from the grid and continue to operate as a standalone system.

Planning and commissioning of this solution is more complicated than Hub-1 due to interaction between the inverter/charger and the grid inverter.

2.3. VE Storage Hub-3

DC electrical power generated by the solar panels is converted to AC by a PV inverter connected to the AC **input** of an inverter/charger.

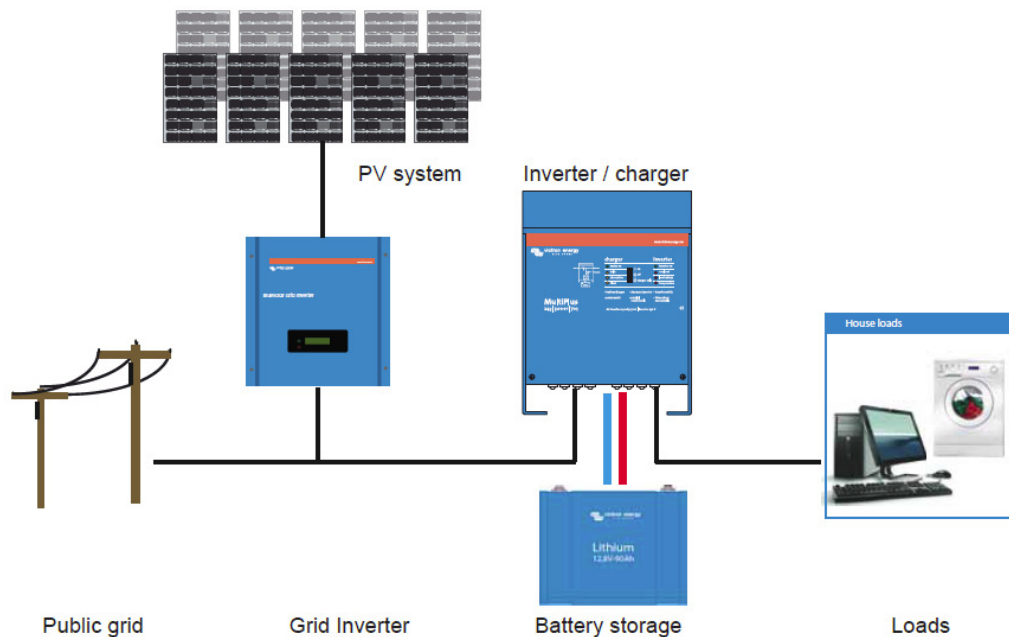

The power from the PV inverter is supplied to the load through the inverter/charger.

In case of insufficient PV power the inverter/charger will supply additional power from the battery, or from the grid.

In case of excess PV power the inverter/charger will use the excess power to recharge the battery.

Once the battery is fully charged the PV inverter will supply excess power to the grid.

If the PV inverter is fitted with an anti islanding device according to local regulations, an anti islanding device is not needed.

In contrast to the Hub-1 and Hub-2 solution the PV inverter will shut down in case of a utility power outage. The Hub will continue to supply the load until the battery is discharged.

3. Essential feature of the three system alternatives: GridAssist

Thanks to GridAssist the inverter/charger can be underrated compared to the expected maximum power required by the load. With GridAssist, the inverter/charger runs synchronized with the grid and whenever AC power required exceeds the capability of the inverter/charger, additional power will be taken from the grid, thus preventing system shut down due to overload.

GridAssist-1

One solution is to run the inverter/charger synchronized, but not connected, with the grid. The connection to the grid (by closing the back feed protection relay in the inverter/charger) is made in case of:

- System overload. Additional power from the grid is used until the load has been reduced to a level that can be managed by the inverter/charger.
- Excess PV or wind power available to be fed back into the grid (if allowed by local regulations).

GridAssist-2

The alternative is to connect the Hub permanently to the grid. The inverter/charger will manage its output to match the load so that the average power taken from the grid is zero, except of course in case of overload or excess power to be fed back into the grid. Warning: stable grid voltage needed!

4. Short description of the main components of the VE Storage Hub

4.1. Battery: lead acid or Li-ion, part 1.

Next to small size and less weight Li-ion (Lithium-iron-phosphate: LiFePO_4 or LFP) is an attractive alternative to lead-acid in grid connected or off grid systems because of efficiency and service life.

Efficiency

The round trip energy efficiency (discharge from 100% to 0% and back to 100% charged) of the average lead-acid battery is 70 to 80%.

The charge process of lead-acid batteries becomes particularly inefficient when 80% state of charge has been reached. Between 80% and 100% charge efficiency is often less than 50%. And these figures become worse in case of high current charging or discharging.

The efficiency of a lead-acid battery comes nowhere near to Li-ion. The efficiency of a LFP battery is around 92%, under all operating conditions.

<http://www.almaden.ibm.com/institute/2009/resources/2009/presentations/ChetSandberg-AlmadenInstitute2009-panel.pdf>

http://people.duke.edu/~kjb17/tutorials/Energy_Storage_Technologies.pdf

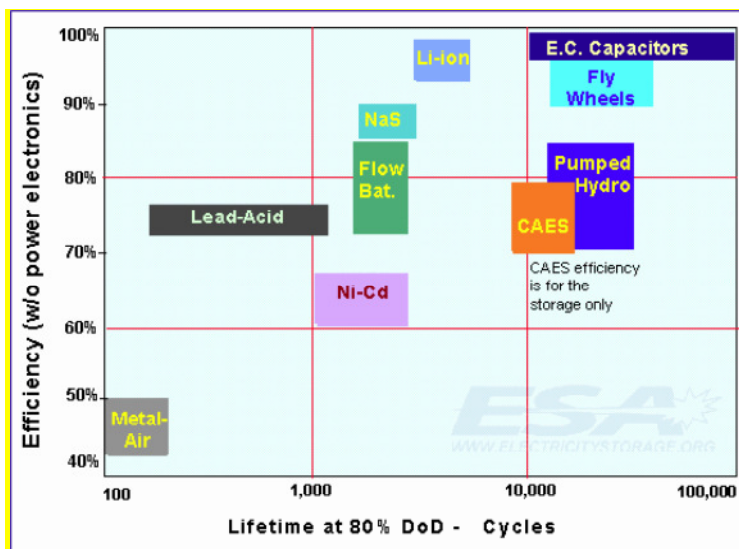

Efficiency of energy storage systems, from

http://catedrasempra.esi.us.es/endesared/documentos/jornada_almacenamiento/Pet_Hall.pdf

Service life

The battery in a PV and/or wind off grid system may suffer from starvation during weeks or even months (wintertime). This is lethal for a lead-acid battery. The battery will fail prematurely due to **sulfation**.

In case of an off grid system with lead acid batteries the constant worry should therefore be battery state of charge: whatever happens, the battery must be fully recharged regularly, and never be left in discharged state during days or weeks.

In a grid connected system the battery can easily be recharged to the full 100% regularly.

Note:

For a discussion of the sulfation problem in solar applications, see for example

http://mnre.gov.in/file-manager/UserFiles/report_batteries_solar_photovoltaic_applications.pdf
(especially the photographs on page 18)

The life span of a LFP battery does not depend on its state of charge, as long as the voltage per battery cell is kept within (broad) limits. A Li-ion BMS (Battery Management System) will do just that, and no battery care whatsoever will be needed.

For more about batteries see section 9.

4.2. MultiPlus and Quattro inverter/chargers

VE inverter/charger range from 800VA to 10kVA single phase, and up to six 10kVA modules can be connected in parallel. All models can be configured for three phase operation.

All MultiPlus and Quattro inverter/chargers can be programmed to seamlessly integrate into Hub-1, -2 or -3.

4.3. BlueSolar MPPT solar charge controller

The charge controller converts DC voltage from the solar array into a voltage suitable to charge the battery. A number of BlueSolar controllers can be connected in parallel, the only limitation being the maximum charge current of the battery (which is very high in case of Li-ion).

The efficiency of a BlueSolar MPPT charge controller exceeds 98%.

4.4. PV inverter

The PV inverter converts DC voltage from the solar array into AC voltage suitable to power the AC loads. In a system without battery, all surplus power will fed back into the grid, and shortage of power will be supplied by the grid.

A PV inverter cannot function without an external AC power source/sink (**ACpss**). The PV inverter will therefore shut down when there is no **ACpss** available (such as a stable grid, suitable inverter or inverter/charger).

5. Electric power consumption at home

A list of the most common home appliances and the amount of electricity they use will help to size the Hub.

Appliance	Power	On-time	Energy/day	Minimum summertime base load for a two person household
Base load (category 1)				
Tropical aquarium with water heater	100 W	24 h	2400 Wh	
High efficiency refrigerator	20 W	24 h	480 Wh	480 Wh
High efficiency freezer (with DC permanent magnet compressor motor)	20 W	24 h	480 Wh	480 Wh
Average refrigerator	50 W	24 h	1200 Wh	
Average freezer	60 W	24 h	1440 Wh	
Plug-in chargers and standby loads	30 W	24 h	720 Wh	720 Wh
Modem	10 W	24 h	240 Wh	240 Wh
Ventilation	30 W	24 h	720 Wh	720 Wh
Electric space heater	2000 W	12 h	24.000 Wh	
Hot water heater (boiler)	3000 W	2 h	6000 Wh	
Central heating (on) and water heater (on)	130 W	8 h	1040 Wh (wintertime, gas fired)	
Central heating (off) and water heater (on)	130 W	2 h	260 Wh	260 Wh
Central heating standby	10 W	24 h	240 Wh	240 Wh
High efficiency lighting	200 W total	6 h (winter) 3 h (summer)	1200 Wh 600 Wh	600 Wh
One 100W traditional incandescent lamp	100 W	6 h (winter) 3 h (summer)	600 Wh 300 Wh	
Electric floor heating in the bathroom	1000 W	3 h	3000 Wh	
Radio	30 W	3 h	90 Wh	90 Wh
LCD TV	50 W	3 h	150 Wh	150 Wh
Large plasma screen TV	300 W	6 h	1800 Wh	
Personal Computer	100 W	3 h	300 Wh	300 Wh
Laptop	30 W	3 h	90 Wh	90 Wh
Range hood	150 W – 300 W	1 h	150 Wh	150 Wh
Total summertime base load, energy conscious two person household				4370 Wh

Other plug in appliances (category 2)

Vacuum cleaner (start-up power 2000 W or more)	1000 W	30 m	500 Wh	500 Wh
Hair dryer	800 W	6 m	80 Wh	80 Wh
Electric jug (energy needed to bring 1 liter water to the boil: 120 Wh)	from 1000 W to 3000 W	Bringing 3 liter water to the boil		360 Wh
Coffee maker	800 W	10 m	120 Wh	120 Wh
Other kitchen appliances (mixer, blender, etc)			100 Wh	300 Wh
Total other plug in appliances, energy conscious two person household				1360 Wh

Appliances always connected to the same socket (category 3)

Washing machine, cold fill	2000 W heater plus 600 W motor		1000 Wh per load
Washing machine, hot fill, average	600 W (peak power)		400 Wh per load
Washing machine, hot fill, best in class	165 W		100 Wh per load
http://www.fisherpaykel.com/admin/pdfs/pdf_usecares/4912_NZ_QuickSmart_WashSmart_UG_hi.pdf			
Clothes dryer with electric heater	3000 W		3000 Wh per load
Clothes dryer with gas heater	300 W		300 Wh per load
Clothes dryer with heat pump	1350 W		1350 Wh per load
http://www.atcoenergysense.com/NR/rdonlyres/635CE05C-6BD3-4421-A1D0-C54CE4DDF20A/0/ManagingElectricityatHomeWebVersion.pdf			
Dish washer, average	2000 W		1100 Wh per cycle
Dish washer with hot fill	1200 W		400 Wh per cycle
http://reg.energyrating.gov.au/comparator/product_types/			
Microwave	2000 W		200 Wh
Electric stove, peak power	8000 W		
Average power during cooking session	2000 W	30 m to 1 h	1000 Wh to 2000 Wh
Electric oven	from 2000 W to 4000 W peak	30 m	2000 Wh
Swimming pool pump	700 W	8 h	5600 Wh
Water well pump	700 W	3 h	2100 Wh
Heat pump heating or cooling (airconditioning)		can be 10 kWh per day or more	

Table 1: Electric footprint of some common home appliances

Base load (category 1)

Some loads will nearly always be present: together these are the base load of the home.

All base loads may be on simultaneously.

It is not easy to reduce the base load. One could insert timers to completely shut down a number of loads during the night and save at most 1 kWh (1 kWh = 1000 Wh).

Because of increased lighting and heating the wintertime base load is substantially higher than the summertime base load.

From table 1:

The reasonable minimum summertime daily base load is	4370 Wh
Peak power to be expected is	660 W
And average power	182 W

During wintertime (in a temperate climate) more lighting and central heating will increase the minimum base load to	5750 Wh
Peak power does not increase	660 W
But average power does increase	240 W

A larger house and/or more people can easily increase the summertime base load to	8000 Wh
And in winter	11.000 Wh

Note:

In a small office or workshop the base load may even be relatively much higher (during working hours) in comparison to the other loads.

Other plug-in appliances (category 2)

Plug-in appliances can be plugged into any socket anywhere in the home. This is especially true for the vacuum cleaner. It is therefore virtually impossible to separate the base load from, especially, the vacuum cleaner with its 1000 W running power and often much higher startup power.

But it is improbable that all plug-in appliances will be used simultaneously.

Appliances always connected to the same socket (category 3)

In most European homes the washing machine and dish washer are cold fill, and the clothes dryer is with electric heater. If used every second day, and not simultaneously, they represent a 3 kW peak load, and together with the microwave only 3 kWh energy required per day, average.

It is often possible to rearrange the wiring so that these loads can be completely separated from the base load and other plug-in appliances.

And one can easily prevent them from being on simultaneously.

Note:

Table 1 shows that a lot can be done to reduce electric energy and (peak) power needed for these appliances.

The classification of loads in three categories does lead to interesting insights and helps discussing the possibilities and limitations of self consumption or off grid operation.

The electric footprint of the three load categories is summarized in table 2 below.

Load category	Two person energy conscious household			The average home			Above average		
	Energy per day Wh	Peak power W	Average power W	Energy per day Wh	Peak power W	Average power W	Energy per day Wh	Peak power W	Average power W
Base load (summer)	4.370	660	182	8.380	1.305	349	18.960	2.560	790
Other plug-in appliances	1.360	2.000	57	1.640	2.000	68	1.920	2.000	80
Appliances always connected to the same socket	350	1.200	15	2.050	3.000	85	7.100	13.100	296
Total (summer)	6.080	3.860	253	12.070	6.305	503	27.980	17.660	1.166
Additional wintertime base load	1380	0	58	2760	0	115	4140	0	173
Total (winter)	7.460	3.860	311	14.830	6.305	618	32.120	17.660	1.338

Table 2: Energy and power per load category

Notes:

1. In case of the two person energy conscious household the most efficient appliance alternatives have been chosen.
2. The average home is inhabited by a family with two children, and fitted with the electric equipment as found in the average European home today.
3. The above average home is about maximum comfort and luxury, including an electric induction cooktop. Heat pump heating and/or cooling (airconditioning) have been left out: a case by case approach is needed because of high energy consumption.
4. In all examples it has been assumed that high power equipment is not in use simultaneously.

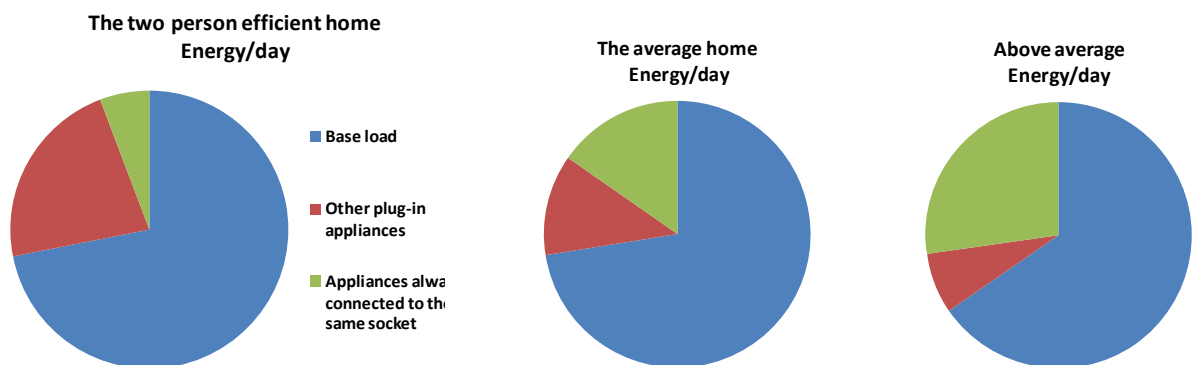

As is clearly shown by the pie charts derived from table 2, the energy and therefore also the average power needed for the base load (blue) is more than two thirds of the total.

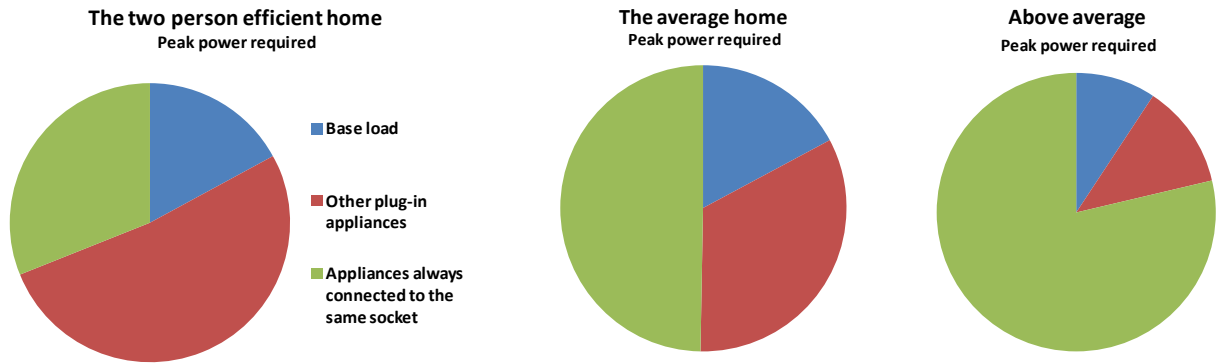

But when looking at peak power required, the base load (blue) is always less than 30% of the total!

In other words: the peak to average load ratio of the base load is much lower than the other two categories, see table 3.

Load category	Two person energy conscious household	The average home	Above average
	Peak/average load	Peak/average load	Peak/average load
Base load (summer)	3,6	3,7	3,2
Other plug-in appliances	35,3	29,3	25,0
Appliances always connected to the same socket	82,3	29,3	42,6
Total (summer)	15,2	11,5	14,7

Table 3: The peak to average load ratio of the three load categories

Conclusion

The **base load** could be powered from the battery with a 1200 VA to 3 kVA inverter.

Category 2 and 3 loads need much more (peak) power when in use, and therefore a more powerful inverter. But they are used during short periods of time only and the resulting energy/day required is low. An inverter supplying the complete home (i. e. all load categories) will therefore operate most of the time at only a few % of its rated power.

In case of the **grid connected home** it would therefore be quite rewarding to power only the base load with an inverter, and connect the other loads to the grid.

In case of the **off grid home** the grid is not available to assist when power hungry appliances are switched on. More inverter power will therefore be needed.

Using electricity to generate heat (washing, drying, cooking) is expensive. Gas and/or solar water heating are lower cost alternatives.

A **load management system** that would switch loads on when the sun is shining can improve self consumption. The loads that that come to mind (see table 1) are:

Hot water heater (boiler)
Swimming pool pump
Water well pump
Washing machine
Clothes drier
Dish washer

But except for the pumps, the better solution is to first reduce electric energy required by these loads by using hot fill (using thermal solar and/or gas heating).

6. Efficiency of the Hub

The Hub sits in between the solar/wind supply and the load. Unfortunately some energy will be lost in the Hub. The losses are not negligible. The purpose of the calculation below is show were these losses come from (answer: the battery!).

The hasty reader can skip the calculation and move directly to the conclusion.

The energy harvested **E_h** should cover the energy **E_i** consumed by the load, plus battery charge/discharge losses, power conversion losses and losses in cabling and fuses.

6.1. If all harvested energy is stored in the battery prior to use

In case of Hub-1, if 0% of the harvested energy is consumed directly by the load (100% of the harvested energy is stored in the battery prior to use), the resulting approximate efficiency $\eta_o = E_i / E_h$ is:

$$\eta_o \approx \eta_i \times \eta_b \times \eta_m \times \eta_w$$

With for example:

94 % AC to DC conversion efficiency of the inverter/charger $\eta_i \approx 0,94$

92% Li-ion battery efficiency $\eta_b \approx 0,92$

98% MPPT charge controller efficiency $\eta_m \approx 0,98$

2% losses in cabling and fuses $\eta_w \approx 0,98$

The result is: $\eta_o \approx 0,83$

With a lead acid battery ($\eta_b \approx 0,8$ or lower, see section 4.1)

The result is: $\eta_o \approx 0,72$ or lower.

And in case of Hub-2 or -3:

$$\eta_o \approx \eta_c \cdot \eta_i \cdot \eta_b \cdot \eta_{pv} \cdot \eta_v$$

With:

94 % AC to DC conversion efficiency of the inverter/charger: $\eta_c \approx 0,94$

94% DC to AC conversion efficiency of the inverter/charger: $\eta_i \approx 0,94$

92% Li-ion battery efficiency: $\eta_b \approx 0,92$

97% PV inverter efficiency: $\eta_{pv} \approx 0,97$

1% losses in cabling and fuses: $\eta_v \approx 0,99$

The result is: $\eta_o \approx 0,78$

With a lead acid battery ($\eta_b \approx 0,8$ or lower, see section 4.1)

The result is: $\eta_o \approx 0,68$ or lower.

6.2. If 40% of the harvested energy is consumed directly by the load

The efficiency η_x will be higher if some of the harvested energy is consumed directly by the load.

In case of Hub-1:

$$\eta_x \approx \eta_i \cdot (X_d + \eta_b \cdot (1 - X_d)) \cdot \eta_m \cdot \eta_w$$

Where X_d is the direct consumption factor.

$X_d = 1$ if all energy is consumed directly, without intermediate storage, and

$X_d = 0$ if all energy is stored prior to use.

If 40% of the harvested energy is consumed directly by the load: $X_d = 0,4$ and $\eta_{40} \approx 0.86$ (with a Li-ion battery)

And in case of Hub-2 or -3:

$$\eta_x \approx (X_d + \eta_c \cdot \eta_i \cdot \eta_b \cdot \eta_c \cdot (1 - X_d)) \cdot \eta_{pv}$$

With 40% of energy consumed directly by the load: $X_d = 0,4$ and $\eta_{40} \approx 0.86$ (with a Li-ion battery)

Notes:

1. Clearly, if a substantial percentage of the harvested energy is consumed directly by the load, the most dramatic efficiency improvement is achieved in case of Hub-2 and-3 because direct consumption not only bypasses the battery, but also the inverter/charger. In practice the improvement will be less pronounced because η_c and η_i are load dependent and decrease when the average load of the inverter/charger becomes low.
2. As indicated in note 1, the efficiencies of the devices constituting the Hub are not constant. The inverter/charger will have a low efficiency at low loads, and maximum efficiency at about 75% of its nominal output power. No load loss is about 1% of nominal output power. The PV inverter and solar charge controller perform better at low loads, with no load losses of approximately 0,2% and 0,05%. Losses in cabling and fuses are proportional to the square of the current flowing through them, resulting in rapidly increasing losses (= decreasing efficiency) at high loads. In fact the efficiency of the Li-ion battery is the most constant of all, being virtually independent of charge/discharge current and state of charge.
3. In case of power from the sun, in most homes direct consumption by the load will be much lower than 40%. Especially if all leave the home to go work or school in the morning and come back late in the afternoon, nearly all consumption (except for the refrigerator and freezer) will take place when PV input is zero. Only when someone stays at home, or in case of a small office, hotel or other business, 40% direct consumption or better can be achieved. Hub-1 will therefore nearly always be the most efficient solution for the PV powered home.

6.3. Conclusion

Due to continuous variation of the load during the day and from one day to the next, it is not possible to accurately calculate the efficiency of the Hub. Moreover, as PV or wind input are in general also subject to wild variations, accurate efficiency calculations are a futile exercise.

In the following examples, 85% efficiency is assumed for systems with a Li-ion battery, and 75% for systems with a lead acid battery.

7. The Hub for the grid connected home

7.1. Powering the base load with Hub-1 and a Li-ion battery

In case of a holiday cabin, small office or home without any category 2 and 3 loads, or if the base load can be separated from all high power appliances (a big if, because an existing home will have to be rewired, and careful planning of the wiring in a new home will be needed) a 800 VA to 3000 VA inverter/charger will be the right choice.

7.1.1. Li-ion battery

If the requirement is to store enough energy to power the base load during one full summer day, 4,4 kWh to 19 kWh of stored energy will be needed (see table 2 or table 6-8 in section 9), plus 6% conversion loss (in the inverter/charger) and plus 20% in order to limit Li-ion battery discharge to 80% (see section 9.3 for max discharge level of batteries).

The total energy storage capacity needed therefore ranges from 5,8 kWh (the two person energy conscious household) to 25 kWh (the above average home).

The capacity of a 24 V Li-ion battery should therefore range from 240 Ah to a whopping 1000 Ah. Better to move to 500 Ah at 48 V in the latter case (see table 8). The battery will not be more expensive, but DC cabling will be cheaper and less cumbersome and the charge controller will produce two times more power at the same output current.

Notes:

- Energy stored in the battery: $E \text{ (kWh)} = Ah \times V \times 1000$.
- In practice not all energy produced during the day will be stored. A certain amount will be consumed directly by the load, resulting in less than 80% battery discharge.
- About cable cross section: cable losses are proportional to $R \cdot I^2$. The current I becomes two times lower when moving from 24 V to 48 V so that cable cross section can be reduced by a factor of four.

7.1.2. Solar array

Here a lot of parameters come into play: suitable surface available, local climate, can excess power be fed back into the grid, etc.

Note:

The solar irradiation on sunny summer days on south facing panels with axis tilt \approx latitude is roughly 8 kWh/m²/day, and relatively independent of latitude.

The average irradiation during a sunny summer month is 6-8 kWh/m²/day.

<http://rredc.nrel.gov/solar/pubs/redbook/>

A solar panel delivers its nominal output power (Wp) at 25°C and 1000 W/m² irradiation.

In a laboratory the daily output of a 1 kWp PV array irradiated at 8 kWh/m²/day will therefore be 8 kWh.

In practice, due to less than perfect orientation, high panel temperature, and particulate build up on the panels, the output of a 1 kWp PV array irradiated at 8 kWh/m²/day will be some 25% lower: 6 kWh instead of 8 kWh.

The assumption in the calculations in the following paragraphs is therefore that on a sunny summer day a 1 kWp array is irradiated with 8 kWh/m²/day and will produce 6 kWh/day, almost all over the world.

<https://www.nvenergy.com/renewablesenvironment/renewablegenerations/documents/PVPerformanceSummary.pdf>

<http://re.jrc.ec.europa.eu/pvgis/apps4/pvest.php>

The average daily output of a solar array will of course depend on the local weather and be lower and often much lower than the sunny summer day output: see table 4.

Latitude	City	Average annual output kWh/kWp	Average annual output/ sunny summer day	Average December* day/ sunny summer day
60	Helsinki, Finland	800	39%	4%
61	Anchorage, AK	800	38%	6%
52	Amsterdam, Netherlands	900	43%	14%
48	Muenchen, Germany	1000	46%	18%
47	Seattle, WA	1000	46%	18%
43	Marseille, France	1500	68%	41%
41	New York, NY	1250	58%	35%
37	Sevilla, Spain	1600	74%	50%
34	Los Angeles, CA	1500	70%	63%
33	Phoenix, AZ	1750	81%	61%
26	Miami, FL	1400	65%	56%

*The worst month in terms of PV output on the Northern Hemisphere

Table 4: Showing the dramatic reduction of PV output as a function of latitude

If, for example, the requirement is to harvest sufficient energy to supply the base load during a sunny summer day, a 850 Wp array will be needed for the two person energy conscious household and around 3700 Wp for the above average home (see table 6-8).

7.1.3. Battery charging

A Blue Solar MPPT 150/70 will take care of a 850 Wp array, together with a 24 V battery (850 Wp* η_m * η_w / 24 V = 34 A charge current needed).

With a 3700 Wp array a 48 V battery is the better choice, and even then two MPPT 150/70 controllers will be needed (3700 Wp* η_m * η_w / 48 V = 74 A charge current needed).

7.1.4. Percentage of electric energy consumption covered by PV when powering the base load with Hub-1 and a Li-ion battery

As can be concluded from table 2 this simple and relatively low cost solution will supply more than 70% of the electric energy needed per day, at least during sunny summer days.

And because PV output will never exceed consumption, feedback into the grid is not needed.

Note:

Depending on latitude and local climate a rough approximation of the average percentage of electric energy consumption covered by PV over the year can be calculated as follows:

Total annual electric energy consumption (see table 6-8):

$$E_y = 365 * (\text{summertime consumption} + \text{wintertime consumption}) / 2$$

Average annual usable PV output (see table 4): $E_{ypv} = kWp * (\text{average annual output}) * (\text{efficiency of the hub})$

$$\text{Percentage covered by PV: } \alpha (\%) = 100 * E_{ypv} / E_y$$

Taking for example the average home, in Sevilla (Spain) or in Amsterdam (The Netherlands):

From table 7: $E_y = 4788$ kWh

From table 4: $E_{ypv} = 1,643 * 1600 * 0,85 = 2234$ kWh (Sevilla) and $1,643 * 900 * 0,85 = 1257$ kWh (Amsterdam)

Percentage covered by PV: $\alpha = 100 * 2234 / 4788 = 47\%$ (Sevilla) and 26% (Amsterdam)

7.1.5. How much self-consumption?

If the solar array is dimensioned to never harvest more energy than required by the base load (plus losses), 100% self-consumption will be achieved.

A lower capacity battery may result in some excess solar energy (once the battery is fully charged).

This excess could be fed back into the grid.

Alternatively the solar array could be downsized in order to match battery capacity.

7.1.6. What happens in case of a discharged battery (wintertime, bad weather)?

The inverter/charger will transfer the load to the grid (interruption free) and shut down. The inverter/charger can be configured to restart after the battery has been partly or fully recharged by the sun and/or wind.

A lead acid battery should not be used in partially discharged state for long periods of time.

A regular full recharge, using power from the grid or a generator is a necessity.

7.1.7. What happens in case of excess production?

This could happen when the home is vacant during the holiday period for example.

Excess power can be fed back into the grid.

If feedback into the grid is not possible, the charge controller will limit power taken from the solar array, after the battery has been fully charged.

7.2. Base load plus other plug-in appliances (category 2 and 3 loads) powered with Hub-1

The simple set up described in the previous section can easily be upgraded to a more performing system by using the GridAssist function.

The maximum AC power pass-through capacity of the MultiPlus models 800, 1200 and 1600 is 3,6 kW (16 A at 230 V). At 2 kVA and above models with 6,9 kW or more pass-through capacity are available. Category 2 loads can therefore be supplied, with some help from the grid. In case of sufficient pass-through capacity the high power category 3 loads could also be supplied by the MultiPlus or Quattro, with help from the grid.

Alternatively, category 3 loads could be wired directly to the grid, bypassing the MultiPlus or Quattro (assuming a single phase grid connection), or could be connected to another phase (in case of a three phase grid connection). **Due to the very short on-time of category 3 loads, bypassing the Hub is a practical solution with limited influence on self-consumption performance.**

Unfortunately bypassing the Hub is not easily feasible with category 2 loads as they are frequently moved from one AC socket to the other (especially the vacuum cleaner).

Note:

Multiplus or Quattro

The Multiplus has one AC input whereas the Quattro has two AC inputs with integrated transfer switch. The Quattro can be connected to two independent AC sources, for example the grid and a generator, or two generators. The Quattro will automatically connect to the active source.

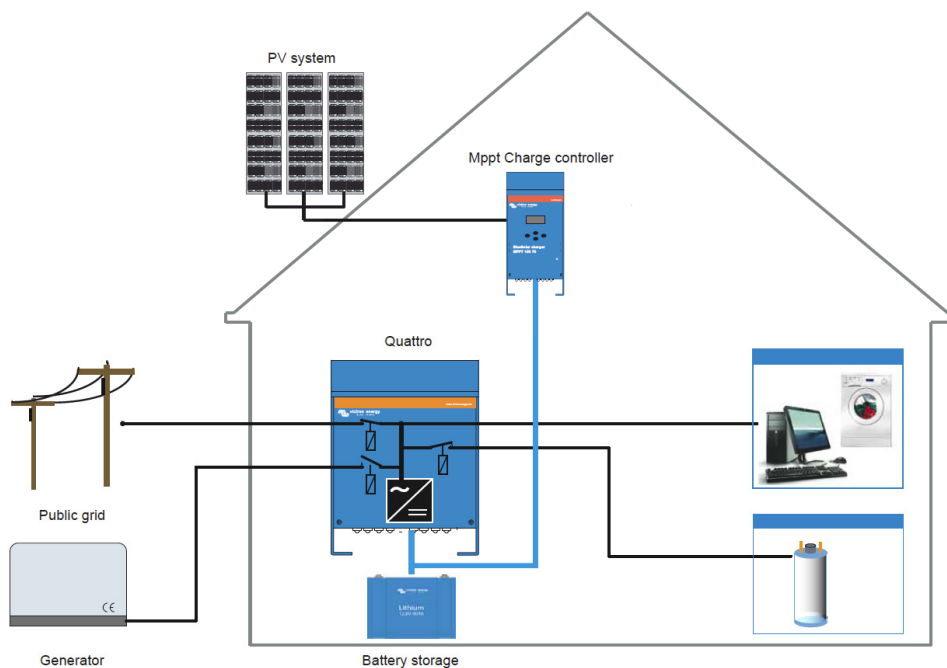

7.2.1. Battery etc

The daily energy required by category 2 and 3 loads is low compared to the base load (see table 2). Battery capacity and PV power therefore must be increased by some 25% to also power these loads on a sunny summer day.

7.2.2. Percentage of electric energy consumption covered by PV

On a sunny summer day approximately 100% of the electric energy needed per day will be covered.

And a rough approximation of the average percentage of electric energy consumption covered by PV over the year can simply be read from table 4 and corrected for losses:

Li-ion battery: $0,85 \cdot 74\% = 63\%$ for Sevilla and $0,85 \cdot 43\% = 37\%$ for Amsterdam.

OPzS battery: $0,75 \cdot 74\% = 56\%$ for Sevilla and $0,75 \cdot 43\% = 32\%$ for Amsterdam.

7.2.3. How much self-consumption?

Only if carefully planned the power consumption of category 2+3 loads will be relatively constant from day to day. Some excess energy may therefore be available on certain sunny summer days, and a shortage on others.

7.3. Powering the base load with Hub-2 or -3

Instead of the solar charge controller, the inverter/charger now charges the battery.

The consequence is that the required charge current may be the determining factor to size the inverter/charger.

A 850 Wp solar array is needed to power the base load of the two person energy conscious home on a sunny summer day (see section 7.1). The resulting maximum charge current (when all harvested power is used to charge the battery) at 24 V is $850 \text{ Wp} \cdot \eta_c \cdot \eta_{pv} \cdot \eta_v / 24 \text{ V} = 32 \text{ A}$.

This means that a 1600 VA MultiPlus will be needed (see table 6).

And the 3700 Wp array for the above average home would require a 8 kVA Quattro (or two 5 kVA Multi's in parallel, or three 3 kVA Multi's in three phase configuration).

With the solar charge controller replaced by a PV inverter and the need for a much bigger inverter/charger, the Hub-2 or -3 alternative is clearly the more expensive solution (and also less efficient: see section 6).

Hub-2 or -3 may nevertheless be the preferred solution if:

- Intermediate power storage is added to a PV array plus PV inverter already installed.
- The relatively low PV voltage needed to supply the charge controller (max 150 V) and therefore increased cable cross section is inconvenient due to long cable runs.

Notes:

- Even with some extra losses in the cabling from the PV array to the solar charge controller, Hub-1 may still be the most efficient solution. See the MPPT 150/70 manual for calculation of DC cable losses.
- A mix of Hub-1 with Hub-2 or -3 is also possible.
- Sensitivity of the PV inverter to AC voltage variations (when power hungry loads are switched) may reduce PV output (due to voltage glitches causing temporary shut downs of the PV inverter).

7.4. Base load plus other plug-in appliances (category 2 and 3 loads) powered with Hub-2 or -3

The more powerful inverter/charger (needed for battery charging, see section 7.3), could supply category 2 and 3 loads without any or with only little help from the grid.

Battery capacity and the PV array would have to be increased by some 25% only to be completely independent of the grid on the now familiar sunny summer day.

Self consumption would be close to 100%.

This achievement has its price: more PV, more battery capacity and a much more powerful inverter/charger needed.

7.5. What about dark and rainy wintertime?

During periods of bad weather (which could last days or even weeks), PV output can be dramatically reduced to not more than a few % of its maximum summertime output, see table 4.

The PV array can be increased to provide sufficient output even during less sunny days, resulting in a surplus to be fed back into the grid on sunny days, but “over sizing” by a factor of ten or more is expensive and requires a large area for the PV array, and is therefore rather unusual.

And increasing battery capacity to ride through weeks of low or near zero output periods is extremely expensive.

The common solutions to compensate for insufficient PV power are therefore:

- Use the power from the grid.
- Install a gas fired micro-CHP (micro combined heat and power) system. The micro-CHP will provide the heat and the electric energy needed when the sun (and/or wind) leaves to desire.
- Install a diesel engine powered generator.

8. The off grid Hub

8.1. Micro-CHP

In densely populated areas, the wish to go off grid can be fulfilled by adding a gas fired micro-CHP to the system.

Generating heat with electricity is easy and the reverse, generating electricity with heat, is not. A micro-CHP with a high electric efficiency is therefore preferable.

The few proven high efficiency micro-CHP systems (25% electricity, 75% heat) are all based on a generator powered by a small **long life internal combustion engine** that runs on natural gas or propane. Electricity produced from the generator is consumed directly or stored in the battery. Simultaneously, the heat from the engine is captured to create thermal energy. The heat is used to for central heating and/or to create hot water.

For more information see for example <http://www.bhkw-infothek.de/>

Stirling engine based systems have a lower electric efficiency (10-15% electricity, 90-85% heat) which may result in excess heat production in a true off grid system.

The **fuel cell** micro-CHP is still a promise for the future.

The electric power output of the micro-CHP should at the very minimum be equal to the average power required. This is not difficult to achieve: even the wintertime average of the above average home is 32,12 kWh per day (see table 8), which is less than 1,4 kW averaged over 24 hours.

If installed in combination with thermal and photovoltaic solar, the micro-CHP will be in use mostly during the winter. The inverter-charger must be sized to power the complete home. As can be seen from table 2, three to sixteen kVA will be needed.

The use of gas for cooking and clothes drying, and hot fill for the washing machine and dish washer is recommended to reduce peak power required.

Battery capacity to cover one day of summertime electricity consumption will be sufficient as the running periods of the micro-CHP can be synchronized with periods of peak electricity consumption.

The micro-CHP will run in parallel with the inverter charger, similar to the PV inverter of Hub-2 or -3. Excess power will be used to recharge the battery, and insufficient power will be supplemented with power from the battery (PowerAssist feature of the MultiPlus and Quattro inverter/charger). The heat (engine heat plus exhaust heat) can be used for the home heating system and to heat the boiler.

When both electric and heat output are fully used, the efficiency of a micro-CHP is around 98%.

(i. e. 98% of the caloric content of the gas burned is transformed in useful heat and electricity).

And with 40% of the electric output directly consumed by the load, the efficiency of the Hub, now including the micro-CHP, will be around 86% in case of a Li-ion battery (see section 6.2).

Note:

In case of the two person **energy conscious household** daily warm water consumption will be 100 to 150 liter (including hot fill dish washer and washing machine), which, when heated to increase temperature by 40°C, requires 5 to 7 kWh of heat.

(specific heat capacity of water: $C = 4,2 \text{ J}/(\text{g}\cdot\text{°K}) \approx 1,2 \text{ Wh}/(\text{liter}\cdot\text{°C})$,

see http://en.wikipedia.org/wiki/Heat_capacity)

At 25% electric efficiency, the micro-CHP will produce $25 / 75 = 0,33$ kWh electric energy per kWh of heat.

With 6 kWh of heat needed, the electric output of the micro-CHP will be 2 kWh.

Counting with 15% loss (85% efficiency) in the hub, the available electric energy is 1,7 kWh.

Total daily electric energy consumption during wintertime is 7,5 kWh/day (see table 6). This means that the micro-CHP will cover roughly 23% of electricity consumption of the two person energy conscious household just when running to produce the required hot water.

If home heating is needed during winter, much more electric energy will be produced:
In The Netherlands the average consumption of natural gas per year for heating a free standing house is 2000 m³.

The caloric content of natural gas is 32 MJ/m³ and 1 kWh = 3,6 MJ.

The average daily energy need during the 6 months that space heating is required is:

$32 \text{ MJ/m}^3 \times 2000 \text{ m}^3 / 182 \text{ days} = 352 \text{ MJ/day}$, or 97 kWh per day.

With 97 kWh of space heating needed per day, the daily electric output of the micro-CHP would be $97 \times 0,33 = 32 \text{ kWh}$.

This happens to be the daily average wintertime daily electric energy consumption of the above average home (see table 8).

Clearly, the micro-CHP is the solution of choice in colder areas where home heating is needed.

8.2. Diesel engine powered generator

In remote areas where power from the grid is not available or not reliable, the traditional solution is to install a diesel engine powered generator (generator). The generator will be rated to cover the highest power requirement expected.

The generator is much cheaper (per rated kVA) and easier to install and service than a micro-CHP, but is noisy, smelly, less efficient (all the heat is wasted!), and needs frequent maintenance.

It also has a much shorter lifespan.

Note:

The traditional diesel powered generator can be modified to more closely resemble a gas powered micro-CHP, mainly by modifications to reduce noise, to decrease maintenance and by adding an engine heat recuperation system.

For more information see <http://www.bhkw-infothek.de/>

When running 24/7 or during most of the day, the traditional diesel engine powered generator solution has two major drawbacks:

Maintenance and service life

Generators need frequent maintenance: oil change every 500 hours, belt replacement every 1000 hours, etc.

Service life of a good 1500 rpm generator is about 10.000 hours (= 3 years when running 24/7).

Fuel consumption at low load

A 10 kW generator will consume between 3 and 3,5 kg of fuel (= 3,7 to 4,4 liter) per hour when powering a 10 kW load.

And at zero load it will still consume 1 kg/h! (see graph 1).

Running a generator 24/7 to power a home, with an average to peak load of less than 10% (see table 3), is therefore an extremely inefficient and expensive solution, because of maintenance and service life per kWh produced, and especially because of extremely high specific fuel consumption (= fuel consumption per kWh produced).

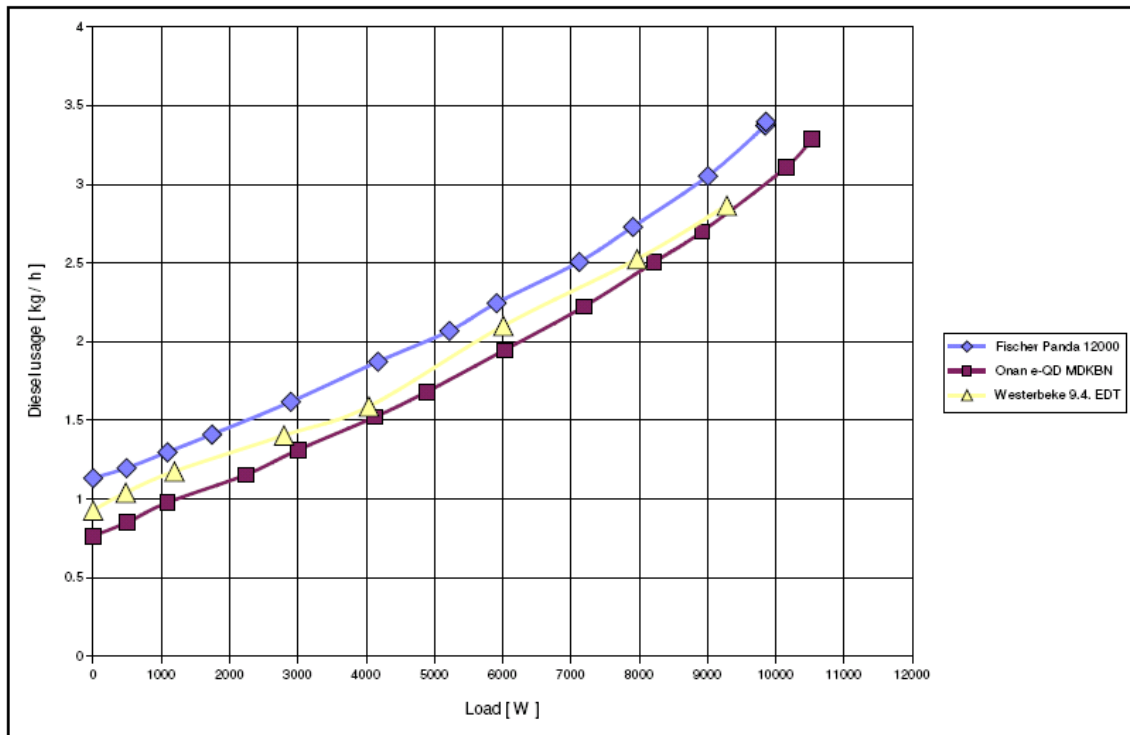

Graph 1: Fuel consumption of three 1500 rpm diesel engine powered generators, max output 9-11 kW

As shown by graph 1, When the generator runs near maximum load (10 kW), specific fuel consumption is around 0,3 kg per kWh.

When operating with 500 W load, specific fuel consumption is around 2 kg per kWh.

A 10 kW generator running 24/7 and burning on average 1kg/hr to power the average home will consume some 9.000 kg (!) of fuel per year to produce the required 4.788 kWh (see table 70).

Without butane or propane gas for cooking and warm water, the all electric solution will increase daily electric energy needed with 8 kWh to 21 kWh, and the average generator load would be close to 1 kW. As can be seen from graph 1, this would only marginally increase fuel consumption, to some 10 ton/year.

And if a bigger generator is installed to cope with potentially higher peak loads, fuel consumption will be even higher.

Graph 2 shows the absolute efficiency of three generators, rated at respectively 3,5 kW, 7 kW and 11 kW. Clearly absolute efficiency is around 25% at the most efficient load point. This means that even when used at their most efficient load point, only 25% of the caloric content of the diesel fuel (the caloric content of automotive diesel fuel is about 45,6 MJ/kg, or 12,7kWh/kg) is converted into electric power. The remaining 75% is transformed into heat and is evacuated through the exhaust and the engine cooling system.

Note:

For more information about generators see the VE Marine Generator Test, downloadable from www.victronenergy.com

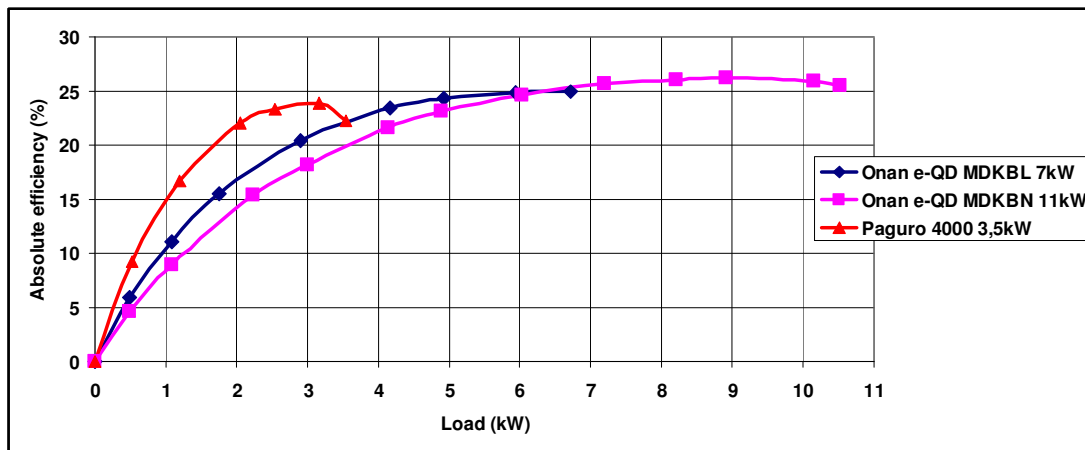

Graph2: Absolute efficiency of three representative generators

As can be seen from graph 2, generator efficiency reduces to 5-10% when operating with 500 W load.

Clearly, there is room for improvement here!

Option 1: adding a low power inverter/charger for nighttime low load periods only

A MultiPlus C 24/1600/40 for example.

The 1600VA inverter will power the base load. A sudden additional load such as a washing machine will however cause the MultiPlus to go into overload protection mode, and the AC supply will shutdown.

To prevent this, the generator must be on-line before any heavy load is switched on.

In practice, this option works well if the inverter/charger supplies the base load during the night, and the generator is on during the day.

With the generator shut down during 8 hours every day, the yearly fuel consumption by the average off grid home would reduce to $10.000 \cdot (24-8) / 24 = 6.700$ kg

Option 2: high power inverter/charger to substantially reduce generator size and running hours

Inverter power should be sufficient to support heavy loads until the generator is on-line.

A load dependent automatic generator start signal can be generated by the inverter/charger. In addition a 'battery discharged' signal to start the generator can be provided by the inverter/charger, a battery monitor or the BMS of the Li-ion battery. Completely automatic system operation is therefore possible.

With reference to table 2 the combined 'Multi/Quattro+generator' rating should be 10 kW to 20 kW.

Now the generator will run only during periods of peak power demand and with help of **PowerAssist** the inverter/charger can be set to operate the generator at its most efficient power point: approximately 80% of its kW nameplate rating. Any excess power available will be used to charge the battery, and insufficient power will be supplemented with power from the battery.

The all electric average home (no butane or propane gas for cooking and warm water) will need on average 21 kWh per day, and assuming 85% efficiency for the Hub with Li-ion battery, total power needed would be $21 / 0,85 = 25$ kWh

With a 10 kVA inverter/charger, generator power could for example be reduced to 7 kVA.

A 7 kVA generator with 4 to 5 kW load will run about 6 hours per day (if no solar/wind input).

Efficiency will be 25%, (0,3 kg of fuel per kWh) and yearly fuel consumption will be $0,3 \text{ kg/kWh} \times 25 \text{ kWh} \times 365 \text{ days} = 2.700$ kg.

Less than one third of the 24/7 solution.

With an OPzS battery, fuel consumption will be $0,3 \text{ kg/kWh} \times (21 / 0,75) \text{ kWh} \times 365 \text{ days} = 3100$ kg.

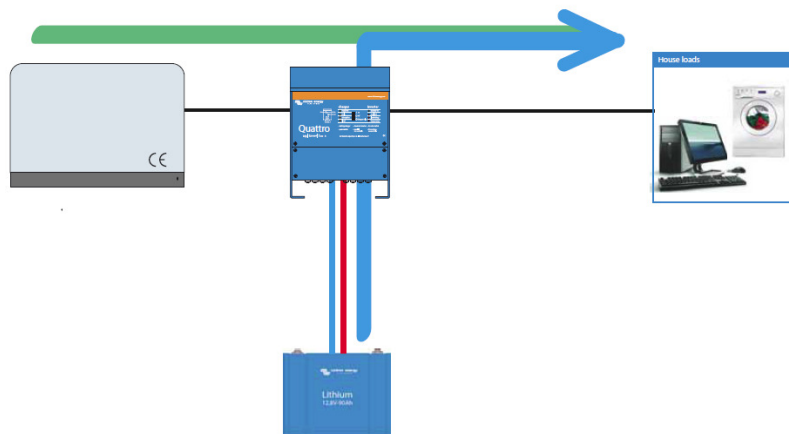

Ok, let's add electric floor heating in the bathroom (3 kWh/day) and a swimming pool (no heating, pump only: 5,6 kWh/day). This would increase yearly fuel consumption to 3.800 kg (Li-ion) or 4.300 kg (OPzS)

Solar and/or wind energy to further reduce running hours

This is of course the next step to further reduce running hours and fuel consumption. Hub-1 and Hub-2 can both be used, but Hub-3 is not an option in this system because the PV inverter will shut down when the generator is not running.

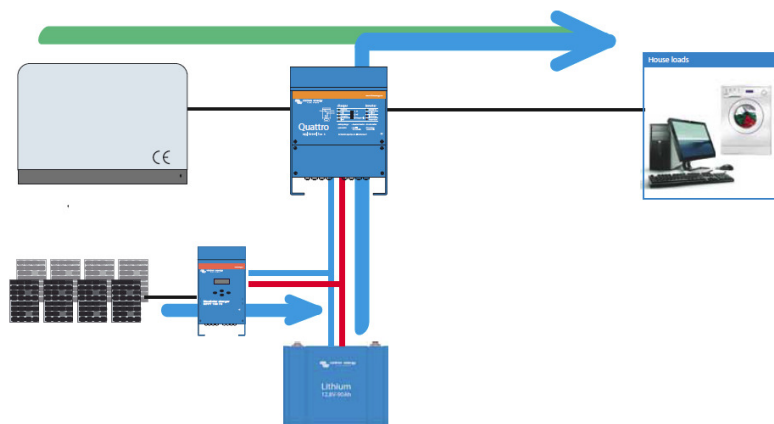

Three phase or single phase generator?

The problem with a (relatively) low power generator is balancing the loads over the three phases. A 10 kVA generator for example can supply 3,3 kVA per phase.

How to connect the loads of the average home?

Connecting the washing machine, clothes dryer and dish washer each to a separate phase would leave very limited power for other loads that could be on simultaneously.

Connecting the washing machine, clothes dryer and dish washer to one phase would be ok as long as they are not used simultaneously. All other appliances could be distributed over the remaining two phases.

In practice extreme situations where one phase is fully loaded or even over loaded and another phase is operating at nearly zero load could often occur.

Wiring all loads to a single phase generator eliminates the load balancing problem.

Three phase pumps

Swimming pool and water well pumps are often three phase, but rated at not more than 3 kVA. The solution is to add a **variable frequency drive with single phase input**. The frequency drive will connect to a single phase supply and also eliminate the starting current peak.

Supplying heavy loads only when the generator is running

During overcast days or wintertime, when solar power has to be supplemented with power from the generator, the generator should be running during periods of high power demand or, alternatively, high power loads (water pumping, water heating) could be switched on when the generator is running.

The Multi and Quattro inverterchargers have a programmable second AC output for this purpose. This output will connect the additional loads with a 1 minute delay to allow the generator to stabilize. **PowerAssist** will take these additional loads into account (which would not be the case if connected directly to the generator).

9. Definition: the 100% PV array and the 100% battery

From section 7.1.2:

The solar irradiation on sunny summer days on south facing panels with axis tilt \approx latitude is roughly 8 kWh/m²/day, and relatively independent of latitude.

With this (very) rough approximation it becomes possible to discuss PV output independently of latitude and local climate, and adjust for local conditions with help of table 4.

With this approximation in mind it can be very clarifying to discuss PV output in units of sunny summer day output (\approx 6 kWh per kWp as discussed in section 7.1.2) and, relating output to consumption, to discuss PV in relation to energy consumption of a home, small office, workshop or any situation where the daily electric energy need ranges from a kWh to 100 kWh.

We therefore will discuss the sunny summer day output of the PV array, and, similarly, the usable storage capacity of the battery, in terms of the daily energy consumption.

A 100% PV array is defined as the array needed to cover 100% of the electric energy consumption of a particular home or similar, on a sunny summer day.

A 50% PV array would cover 50% of energy consumption, on a sunny summer day.

Similarly, a 100% battery is a battery with sufficient usable storage capacity to store the energy needed for one summer day.

10. Cost

10.1. Self-consumption: optimal storage capacity

Self-consumption is a relatively new phenomenon. Its increasing popularity is driven by increasing retail electricity prices and simultaneously decreasing feed in tariffs. Selling excess PV energy for, let's say 15 Eurocents per kWh at noon and buying it back in the evening for 25 Eurocents seems like a bad deal. Better to store the excess for later use.

From a purely financial point of view, intermediate storage would be an interesting proposition if the additional cost involved is lower than the cost incurred by selling electricity at low price and buying it back later at a higher price.

A reasonably accurate financial justification for intermediate storage is not easily made. Except for desert low latitude regions where the sun is shining every day, PV output will be subject to wild variations from day to day and from season to season. Installing a PV array plus energy storage covering 100% of the energy need on a sunny summer day (the 100% self consumption solution) is certainly not optimal in high latitude regions: the battery will be oversized on overcast days and will even be sitting idle on dark winter dater days when PV output is close to zero.

What can safely be stated is:

- The (financially) optimal storage capacity increases with increasing difference between the retail electricity price and the feed in tariff.
- The optimal storage capacity decreases with latitude (and also depends on the local climate).
- The optimal storage capacity increases when system cost decreases.

As we have not (yet) devised a simple method to at least compute a rough approximation of optimal intermediate storage capacity, we simply assume it to be around 30% of the sunny summer day output of the PV array.

Another point is that self-consumption is required to ensure stability of the grid. A system with limited storage capacity will however behave just like a system without intermediate storage once the battery has been fully charged. On a sunny summer day, the battery may for example be fully charged before noon and be of no use to attenuate fluctuations and limit feed back when needed most.

One may therefore expect that in the near future a limit of one sort or another will be set to the amount of power that may be fed back into the grid.

The limit may for example be that feedback should never exceed a percentage of the Pw rating of the array. With a limit of 60%, for example, feedback power should not exceed 60% of installed PV power.

A rough approximation of the energy that would be wasted or could better be stored in a battery as a result of such a regulation is calculated below:

Assuming that the output from the array can be approximated by a half circle (starting at zero in the morning, increasing to maximum output at noon and back to zero in late afternoon), the energy that must not be fed back into the grid (or could be fed back later on the day) is represented by the green circular segment in figure 5.

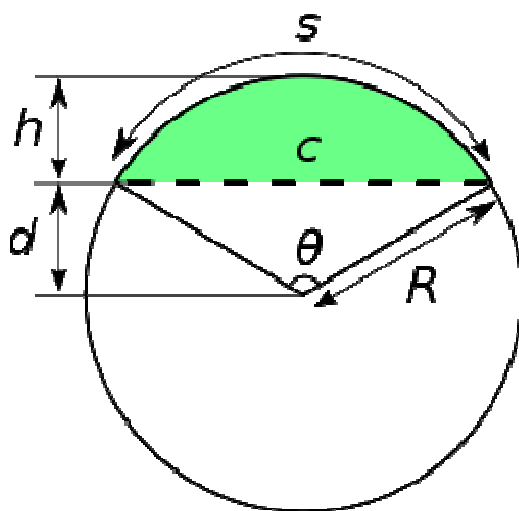

Figure 5: Limiting peak power fed back into the grid

With $P_w = R = 1$, $d \cdot P_w$ is the maximum power that can be fed back into the grid.

The area A of the green circular segment is

$$A = (R^2/2) \cdot (\theta - \sin\theta) \quad \text{with } \theta = 2 \arccos \frac{d}{R}$$

(see http://en.wikipedia.org/wiki/Circular_segment)

And the area of the half circle is $C = (\frac{1}{2}) \cdot \pi R^2$

With these formulas the percentage that must be “shaved off” to limit feedback to $d \cdot P_w$ for different values of d can be calculated:

$$d = 0,6: A/C = 0,45/1,57 \approx 0,3$$

$$d = 0,5: A/C = 0,61/1,57 \approx 0,4$$

$$d = 0,4: A/C = 0,79/1,57 \approx 0,5$$

(see <http://www.handymath.com/cgi-bin/arc18.cgi>)

If $d = 0,6$ (meaning that feedback into the grid should never exceed 60% of the P_w rating of the array), the green area represents 30% of the half circle, and therefore at least 30% of the array output must be absorbed by the load and/or stored in the battery.

In this case, assuming zero load, 100% system efficiency and a discharged battery in the morning, **battery storage could be reduced to 30%** of the sunny summer day PV output while still satisfying the (hypothetical) regulation for self consumption. The battery would then be used to store the energy content of the green area while the remaining output from the solar array could be fed back into the grid.

Note:

The alternative is to simply limit output of the grid inverter to 60% of P_w installed: no storage needed, and 30% of the potential output of the array will be wasted on sunny summer days.

10.2. Off-grid: optimal storage capacity

When a micro-CHP or generator is available, sufficient usable capacity to cover one full day is the generally accepted norm.

If sun and/or wind are the only sources of energy, a combination of oversized PV and/or wind output and oversized battery capacity (ie more than 100% as defined in section 9) will be needed to cover periods with low PV/wind output.

10.3. Battery: lead acid or Li-ion, part 2

10.3.1. Lithium iron phosphate

A Lithium iron phosphate (LiFePO_4 or LFP) battery should preferably not be discharged to less than 20% of its rated capacity. It can be discharged about 2000 times to 20%, and it can be recharged at high current up to nearly 100% (discharging regularly to less than 20% would reduce cycling endurance disproportionately).

The useful Ah (and kWh) capacity is therefore 80% of its nominal rating.

10.3.2. Tubular plate lead acid

Tubular plate lead acid batteries, whether flooded (OPzS: Ortsfeste Panzerplatte mit Spezialeseparator) or gel (OPzV) are quite robust, and have proven to perform extremely well in off grid systems. This according to our own experience as well as several tests:

<http://www.cres.gr/kape/publications/photovol/5BV-335.pdf>

http://www.iea-pvps.org/index.php?id=9&eID=dam_frontend_push&docID=376

They can regularly be discharged to 30% of their C_{10} capacity but charge efficiency becomes very low and charge current acceptance reduces appreciably once the battery has been charged up to 80%.

These batteries should therefore be cycled between 80% and 30%, and regularly be recharged to the full 100% to prevent sulfation.

A second reason to regularly fully recharge the OPzS battery is acid stratification. (http://batteryuniversity.com/learn/article/water_loss_acid_stratification_and_surface_charge/) OPzS and OPzV batteries have a high internal resistance and therefore efficiency and available capacity will be reduced substantially at high charge and discharge currents. (for specifications see <http://www.victronenergy.com/upload/documents/Datasheet%20-%20OPzS%20batteries%20-%20rev%2004%20-%20EN.pdf>)

10.3.3. Flat plate flooded and flat plate VRLA lead acid

Many different types of flat plate flooded and VRLA (valve regulated lead acid: gel and AGM) batteries are available, and, generally speaking, the best ones are also the most expensive. According to our experience they however all are less robust than tubular plate OPzV and especially OPzS batteries in terms of cycling capability as well as sulfation risk.

Victron Energy sells a range of deep discharge flat plate VRLA (Gel and AGM) batteries which have thicker plates than car batteries and than the lowest cost VRLA batteries. This results in reasonable cycling performance, but does not eliminate sulfation risk.

(for specifications see <http://www.victronenergy.com/upload/documents/Datasheet%20-%20GEL%20and%20AGM%20Batteries%20-%20rev%2007%20-%20EN.pdf>)

It is advisable limit discharge of these batteries to 50% of their C₂₀ capacity rating.

Similarly to tubular plate batteries, charge efficiency becomes very low and charge current acceptance reduces appreciably once the battery has been charged up to 80%.

These batteries should therefore be cycled between 80% and 50%, and regularly be recharged to the full 100% to limit sulfation.

A comparison between different batteries is given in the table below.

	Flat plate AGM	Tubular plate flooded (OPzS)	Tubular plate gel (OPzV)	Li-ion LiFePO ₄
Cost per rated kWh	€ 188	€ 312	€ 432	€ 1.233
Usable capacity	30%	50%	50%	80%
Cost per usable kWh	€ 627	€ 624	€ 864	€ 1.541
Efficiency @ I = 0,1C ²	80%	80%	80%	92%
Efficiency @ I = 0,5C	70%	60%	60%	92%
Cycle life @ 25°C	750 - 1500 ¹	2500	2000 - 2500	2000
Volume per usable kWh	11,3 cm ³	15,4 cm ³	15,4 cm ³	8,7 cm ³
Weight per usable kWh	82 kg	82 kg	82 kg	17 kg
Application	seasonal use - off grid holiday house	year round cycling - homes, small offices, workshops, etc	year round cycling - homes, small offices, workshops, etc	year round cycling - homes, small offices, workshops, etc
Can be installed in the living area	yes	no	yes	yes
Regular full recharge needed	yes	yes	yes	no
regular maintenance needed	no	yes	no	no

Notes:

- 1) As a result of their relative fragility, low cost flat plate AGM and gel batteries (and to a lesser extent OPzV) in practice rarely reach the number of cycles (1500) that can be achieved in laboratory conditions.
- 2) 0,1C means a charge and discharge current of 0,1 times the rated capacity in Ah. For a 100 Ah battery this current would be 10 A

Table 5: Battery comparison

10.4. The PV array

The recent world wide reduction of feed in tariffs has resulted in over capacity instead of shortage of PV panels and a dramatic price reduction.

As can be concluded from the table 6-8 the cost of the 100% PV array is around 20% of the total cost, while the 100% Li-ion battery represents 70% of the total.

If the available (roof-) area is no constraint, the PV array can be enlarged substantially with limited effect on total cost.

If local regulations reward feedback into the grid this should obviously be done. Doubling the area would result in 50% self consumption on a sunny summer day, and up to 45 degrees latitude sufficient energy would be harvested during most of the year to power the home (depending on local climate, see table 4).

And even if local regulations do not reward or even prohibit feedback into the grid, it could be advantageous to have some excess capacity on sunny summer days in order to harvest more energy on other days.

10.5. Examples: cost of the major components

The tables below detail the options as discussed for self consumption, with a cost indication of each of the major components, based on Victron Energy recommended consumer prices.

10.5.1. To summarize:

Three homes were discussed, each detailed in one of the following tables:

The two person energy conscious household

The average home

The above average home

With these three examples the requirements and cost for other applications, such as a small office or workshop, can easily be defined.

The spreadsheet with which the tables were created can be downloaded from

www.victronenergy.com.

For each home three types of loads were identified:

Category 1: the base load, mainly consisting of low power appliances that are switched on permanently or during long periods of time every day. The base load therefore has a low kW/kWh ratio and can efficiently be powered by a battery plus low power inverter. The base load is by far the largest electricity consumer in the home.

Category 2: plug-in appliances, which can easily be moved from one socket to another (especially the vacuum cleaner) and are used during short periods of time. These loads have a high kW/kWh ratio but cannot easily be separated from the base load.

Category 3: non movable loads that are always connected to the same socket. It is sometimes possible to bypass the Hub and connect these loads directly to the grid, thereby reducing peak power required. Peak electric power required can also be reduced by using thermal solar and/or gas instead of electricity for heating purposes.

With a **load management system** several category 3 loads can be switched on when the sun is shining, thereby increasing self consumption without additional battery storage capacity needed.

10.5.2. The first three tables (table 6-8) reflect the examples as discussed in section 7

- **PV array:**
The PV array has been sized to harvest sufficient energy to supply 100% of the required energy by one or more load categories on a sunny summer day.
The rationale behind this choice is that:
 - On a sunny summer day the energy harvested from a solar panel is about the same, all over the world. The tables are therefore universally applicable.
 - With sufficient battery storage, self consumption will be close to 100%, even on a sunny summer day. The consequence is that on all other days of the year the amount of energy harvested will not be sufficient to cover consumption. Additional energy has to be supplied by the grid. Self consumption, however, will always be 100%.
- **Li-ion battery:**
The Li-ion battery has been sized to store the energy required for one or more load categories during one summer day. Year round 100% self consumption is therefore ensured. But the battery will be over dimensioned on all those days of the year when less energy is harvested.

The Li-ion battery clearly is by far the most expensive part of the system.

10.5.3. Table 9 to 11: the three homes, with OPzS battery

- **OPzS Battery:**
In these tables the Li-ion battery has been replaced by an OPzS battery, again sized to store the energy required for one or more load categories on a sunny summer day. Year round 100% self consumption is therefore ensured. But the battery will be over dimensioned on all those days of the year when less energy is harvested. The nominal energy storage capacity is higher because useful capacity reduces to 50% in comparison to 80% in case of the Li-ion battery (see section 10.3.3).
- **PV array:**
The PV array has again been sized to harvest sufficient energy to supply 100% of the required energy by one or more load categories on a sunny summer day.
The slightly larger array Pw reflects the lower efficiency of the OPzS battery compared to Li-ion.

Total system cost is nevertheless much lower than the Li-ion option.

With 100% battery storage and 100% PV, the column labeled category 1+2+3 in tables 6 to 11 is representative for an off grid situation with sufficient PV power to avoid running the micro-CHP or generator on sunny summer days. Running hours of the micro-CHP or generator can be further reduced by over sizing the PV array and/or battery.

10.5.4. Table 12 to 14: Battery energy storage reduced to 30% of PV output

Table 12 to 14 each consist of 5 sub tables which summarize cost for several battery and PV solutions.

The first sub tables (a) are a concentrated version of table 6 to 8.
The Li-ion battery and the PV array are both sized at 100%.

The following three sub tables (b, c and d) are based on a self consumption regulation stipulating that at most 60% of the Wp power of the array may fed back into the grid. As shown in section 10.1, battery storage can then be reduced to approximately 30% of the sunny day kWh array output. In sub tables b the size of the PV array has been kept at 100% and battery storage was therefore reduced to 30%.

In sub tables c and d the PV array has been increased to respectively 200% and 300%, and battery storage has been increased accordingly.

In sub tables e the PV array was again sized at 300% but the Li-ion battery has been replaced with a OPzS battery, sized at 100%.

Note:

Regarding system efficiency the matter becomes complicated as soon as the battery becomes too small to store the daily energy harvest from the sun (or wind), as will be the case when battery storage is reduced to 30% of the sunny day PV array output. In that case some of the potential energy harvest will be wasted (if feedback into the grid is not possible), or will be directly consumed by the load (if there is a load), or will be fed back into the grid, bypassing the battery.

Direct feedback into the grid does increase efficiency (no losses due to battery cycling), and simultaneously decreases self consumption.

Note:

Not every day is a sunny summer day, in most regions. When less energy is harvested, relatively more energy will “go through” the battery, decreasing efficiency but increasing self consumption.

To keep things simple the sub tables have been created assuming that 100% of the harvested energy goes through the battery. This assumption may be close to reality in high latitude areas with few sunny days, but is pessimistic (with regard to efficiency) in case of sunny low latitude areas.

If we take Sevilla (Spain) for example, table 4 shows that the average annual output is 74% of the sunny summer day output. If the battery is sized to store 30% of the sunny summer day PV output, roughly $74\% - 30\% = 44\%$ will be fed back into the grid and/or supply a load, bypassing the battery and the related losses (8% in case of Li-ion and approximately 20% in case of lead acid).

Note:

Battery capacity will slowly reduce with time. The generally accepted end-of-life capacity is 80% of the name plate capacity. In order to have the required capacity still available when the battery reaches end-of-life, a new battery should be overrated by a factor $1/0,8 = 1,25$. This factor is not included in the energy storage capacity as calculated in the following tables.

Two person energy conscious household		Category 1	Category 1+2	Category 1+2+3
Li-ion battery		(base load)	(plus pluggable loads)	(the complete home)
Electric energy consumption				
Summertime	S	4,37	5,73	6,08 kWh
Wintertime	W	5,75	7,11	7,46 kWh
Annual	$E_y = 365*(S+W)/2$	1801	2286	2410 kWh
Li-ion battery with sufficient storage capacity to store 100% of the daily summertime electric energy consumption				
Energy storage capacity	$S/(0,80*0,94)$	5,81	7,62	8,09 kWh
Nominal voltage		24	24	24 V
Ah storage capacity	E_{sc}/N_v	242	317	337 Ah
Cost	1233 €/kW	€ 7.165	€ 9.395	€ 9.969
Solar array with sufficient output to supply 100% of the load during a sunny summer day				
Required daily Hub output	S^* 1	4,37	5,73	6,08 kWh/day
Required daily PV output	$R_d H_o / 0,85$	5,14	6,74	7,15 kWh
Array Wp	$R_d P V_o / 6$	857	1124	1192 Wp
Cost	2,19 €/Wp	€ 1.877	€ 2.461	€ 2.611
Hub-1				
Efficiency solar charge controller + DC cables	$\eta_m * \eta_w$	96	96	96 %
Max. Charge current	$\eta_m * \eta_w * A_{wp} / N_v$	34	45	48 A
Solar charge controller	MPPT 70/50	€ 260	MPPT 70/50 € 260	MPPT 70/50 € 260
Max. Load	L	660	2660	2660 W
Inverter/charger	Multi	Multi	Multi	Multi
GridAssist needed			24/2000/50 € 1.454	24/2000/50 € 1.454
GridAssist not needed		24/1200/25 € 969	24/3000/70	24/3000/70
Hub-1: cost of the major components		€ 10.271	€ 13.570	€ 14.294
Hub-2 or -3				
PV inverter		1,5 kW € 1.149	1,5 kW € 1.149	1,5 kW € 1.149 kW
Efficiency PV inverter + Inverter/charger	$\eta_c * \eta_{pv} * \eta_v$	90	90	90 %
Max. Charge current	$\eta_c * \eta_{pv} * \eta_v * A_{wp} / N_v$	32	42	45 A
Max. Load	L	660	2660	2660 W
Inverter/charger	Multi	Multi	Multi	Multi
GridAssist not needed		24/1600/40 € 1.163	24/3000/70 € 2.180	24/3000/70 € 2.180
Hub-2 or -3: cost of the major components		€ 11.354	€ 15.185	€ 15.909

Table 6: The two person energy conscious household
100% Li-ion battery and 100% PV

The column labeled Category 1+2+3 includes the non movable loads (= appliances always connected to the same socket).

In this example the non movable loads consume, on average, only 350 Wh per day.

This is because the following choices were made:

- best in class hot fill washing machine
- gas heated clothes dryer
- hot fill dish washer
- gas fired cooktop
- gas fired central heating and boiler

The average home		Category 1	Category 1+2	Category 1+2+3
Li-ion battery		(base load)	(plus pluggable loads)	(the complete home)
Electric energy consumption				
Summertime	S	8,38	10,02	12,07 kWh
Wintertime	W	11,14	12,78	14,83 kWh
Annual	$E_y = 365 \cdot (S+W)/2$	3475	4058	4788 kWh
Li-ion battery with sufficient storage capacity to store 100% of the daily summertime electric energy consumption				
Energy storage capacity	$S/(0,80 \cdot 0,94)$	11,14	13,32	16,05 kWh
Nominal voltage		24	48	48 V
Ah storage capacity	E_{sc}/N_v	464	278	334 Ah
Cost	1233 €/kW	€ 13.740	€ 16.429	€ 19.790
Solar array with sufficient output to supply 100% of the load during a sunny summer day				
Required daily Hub output	S^* 1	8,38	10,02	12,07 kWh/day
Required daily PV output	$RdHo/0,85$	9,86	11,79	14,20 kWh
Array Wp	$RdPVo/6$	1643	1965	2367 Wp
Cost	2,19 €/Wp	€ 3.598	€ 4.303	€ 5.183
Hub-1				
Efficiency solar charge controller + DC cables	$\eta_m \cdot \eta_w$	96	96	96 %
Max. Charge current	$\eta_m \cdot \eta_w \cdot A_{wp}/N_v$	66	39	47 A
Solar charge controller		MPPT 150/75 € 720	MPPT 150/75 € 720	MPPT 150/75 € 720
Max. Load	L	1305	3305	3805 W
Inverter/charger		Multi	Multi	Multi
GridAssist needed				48/3000/35 € 2.180
GridAssist not needed		24/2000/50 € 1.454	48/3000/35 € 2.180	48/5000/70 € 2.907
Hub-1: cost of the major components		€ 19.513	€ 23.632	€ 27.873
Hub-2 or -3				
PV inverter		2 kW € 1.393	2 kW € 1.393	2,8 kW € 1.670 kW
Efficiency PV inverter + Inverter/charger	$\eta_c \cdot \eta_{pv} \cdot \eta_v$	90	90	90 %
Max. Charge current	$\eta_c \cdot \eta_{pv} \cdot \eta_v \cdot A_{wp}/N_v$	62	37	45 A
Max. Load	L	1305	3305	3805 W
Inverter/charger		Multi	Multi	Multi
GridAssist not needed		24/3000/70 € 2.180	48/3000/35 € 2.180	48/5000/70 € 2.907
Hub-2 or -3: cost of the major components		€ 20.912	€ 24.305	€ 29.550

Table 7: The average home
100% Li-ion battery and 100% PV

The column labeled Category 1+2+3 includes non movable loads (= appliances always connected to the same socket) which, in this example, consume on average 2050 Wh per day:

- washing machine with electric water heater
- clothes dryer with electric heater
- dish washer with electric water heater
- gas fired cooktop
- gas fired central heating and boiler

The above average home		Category 1	Category 1+2	Category 1+2+3	
Li-ion battery		(base load)	(plus pluggable loads)	(the complete home)	
Electric energy consumption					
Summertime	S	18,96	20,88	27,98	kWh
Wintertime	W	23,10	25,02	32,12	kWh
Annual	$E_y = 365 \cdot (S+W)/2$	7487	8170	10698	kWh
Li-ion battery with sufficient storage capacity to store 100% of the daily summertime electric energy consumption					
Energy storage capacity	$S/(0,80 \cdot 0,94)$	25,21	27,77	37,21	kWh
Nominal voltage		48	48	48	V
Ah storage capacity	E_{sc}/N_v	525	578	775	Ah
Cost	1233 €/kW	€ 31.087	€ 34.235	€ 45.877	
Solar array with sufficient output to supply 100% of the load during a sunny summer day					
Required daily Hub output	S^*	18,96	20,88	27,98	kWh/day
Required daily PV output	$RdHo/0,85$	22,31	24,56	32,92	kWh
Array Wp	$RdPVo/6$	3718	4094	5486	Wp
Cost	2,19 €/Wp	€ 8.142	€ 8.966	€ 12.015	
Hub-1					
Efficiency solar charge controller + DC cables	$\eta_m \cdot \eta_w$	96	96	96	%
Max. Charge current	$\eta_m \cdot \eta_w \cdot A_{wp}/N_v$	74	82	110	A
Solar charge controller		MPPT 150/75 € 720	2*MPPT 150/75 € 1.440	2*MPPT 150/75 € 1.440	
Max. Load	L	2560	4560	10560	W
Inverter/charger		Multi	Multi	Multi	
GridAssist needed			48/3000/35 € 2.180	48/5000/70 € 2.907	
GridAssist not needed		48/3000/35 € 2.180	48/5000/70	48/10000/140	
Hub-1: cost of the major components		€ 42.129	€ 46.822	€ 62.239	
Hub-2 or -3					
PV inverter		5 kW € 2.554	5 kW € 2.554	8 kW € 4.000	kW
Efficiency PV inverter + Inverter/charger	$\eta_c \cdot \eta_{pv} \cdot \eta_v$	90	90	90	%
Max. Charge current	$\eta_c \cdot \eta_{pv} \cdot \eta_v \cdot A_{wp}/N_v$	70	77	103	A
Max. Load	L	2560	4560	10560	W
Inverter/charger		Multi	Multi	Multi	
GridAssist not needed		48/5000/70 € 2.907	48/8000/110 € 4.748	48/10000/140 € 5.233	
Hub-2 or -3: cost of the major components		€ 44.690	€ 50.504	€ 67.125	

Table 8: The above average home
100% Li-ion battery and 100% PV

The column labeled Category 1+2+3 includes non movable loads (= appliances always connected to the same socket) which, in this example, consume on average 7100 Wh per day:

- washing machine with electric water heater
- clothes dryer with electric heater
- dish washer with electric water heater
- electric induction cooktop
- gas fired central heating and boiler

Two person energy conscious household		Category 1	Category 1+2	Category 1+2+3
OPzS battery		(base load)	(plus pluggable loads)	(the complete home)
Electric energy consumption				
Summertime	S	4,37	5,73	6,08 kWh
Wintertime	W	5,75	7,11	7,46 kWh
Annual	$E_y = 365 \cdot (S+W)/2$	1801	2286	2410 kWh
OPzS battery with sufficient storage capacity to store 100% of the daily summertime electric energy consumption				
Energy storage capacity	$S/(0,50 \cdot 0,94)$	9,30	12,19	12,94 kWh
Nominal voltage		24	24	24 V
Ah storage capacity	Esc/Nv	387	508	539 Ah
Cost	312 €/kW	€ 2.901	€ 3.804	€ 4.036
Solar array with sufficient output to supply 100% of the load during a sunny summer day				
Required daily Hub output	$S^* 1$	4,37	5,73	6,08 kWh/day
Required daily PV output	$RdHo/0,75$	5,83	7,64	8,11 kWh
Array Wp	$RdPVo/6$	971	1273	1351 Wp
Cost	2,19 €/Wp	€ 2.127	€ 2.789	€ 2.959
Hub-1				
Efficiency solar charge controller + DC cables	$\eta_m \cdot \eta_w$	96	96	96 %
Max. Charge current	$\eta_m \cdot \eta_w \cdot A_{wp}/N_v$	39	51	54 A
Solar charge controller		MPPT 70/50	MPPT 70/50	MPPT 70/50
		€ 260	€ 260	€ 260
Max. Load	L	660	2660	2660 W
Inverter/charger		Multi	Multi	Multi
GridAssist needed			24/2000/50	24/2000/50
		€ 969	€ 1.454	€ 1.454
GridAssist not needed		24/1200/25	24/3000/70	24/3000/70
		€ 6.257	€ 8.306	€ 8.709
Hub-1: cost of the major components				
Hub-2 or -3				
PV inverter		1,5kW	1,5kW	1,5kW kW
Efficiency PV inverter + Inverter/charger	$\eta_c \cdot \eta_{pv} \cdot \eta_v$	90	90	90 %
Max. Charge current	$\eta_{pv} \cdot \eta_v \cdot A_{wp}/N_v$	32	42	45 A
Max. Load	L	660	2660	2660 W
Inverter/charger		Multi	Multi	Multi
GridAssist not needed		24/1600/40	24/3000/70	24/3000/70
		€ 1.163	€ 2.180	€ 2.180
Hub-2 or -3: cost of the major components				
		€ 7.340	€ 9.921	€ 10.324

Table 9: The two person energy conscious household
100% OPzS battery and 100% PV

The column labeled Category 1+2+3 includes the non movable loads (= appliances always connected to the same socket).

In this example the non movable loads consume, on average, only 350 Wh per day.

This is because the following choices were made:

- best in class hot fill washing machine
- gas heated clothes dryer
- hot fill dish washer
- gas fired cooktop
- gas fired central heating and boiler

Note:

In order to reduce the number of battery cells and increase Ah per cell, a lower DC system voltage is sometimes preferred.

The average home		Category 1	Category 1+2	Category 1+2+3	
OPzS battery		(base load)	(plus pluggable loads)	(the complete home)	
Electric energy consumption					
Summertime	S	8,38	10,02	12,07	kWh
Wintertime	W	11,14	12,78	14,83	kWh
Annual	$E_y = 365 \cdot (S+W)/2$	3475	4058	4788	kWh
OPzS battery with sufficient storage capacity to store 100% of the daily summertime electric energy consumption					
Energy storage capacity	$S/(0,50 \cdot 0,94)$	17,83	21,32	25,68	kWh
Nominal voltage		24	48	48	V
Ah storage capacity	Esc/Nv	743	444	535	Ah
Cost	312 €/kW	€ 5.563	€ 6.652	€ 8.012	
Solar array with sufficient output to supply 100% of the load during a sunny summer day					
Required daily Hub output	$S^* \cdot 1$	8,38	10,02	12,07	kWh/day
Required daily PV output	$RdHo/0,75$	11,17	13,36	16,09	kWh
Array Wp	$RdPVo/6$	1862	2227	2682	Wp
Cost	2,19 €/Wp	€ 4.078	€ 4.876	€ 5.874	
Hub-1					
Efficiency solar charge controller + DC cables	$\eta_m \cdot \eta_w$	96	96	96	%
Max. Charge current	$\eta_m \cdot \eta_w \cdot A_{wp}/N_v$	75	45	54	A
Solar charge controller		MPPT 150/75	MPPT 150/75	MPPT 150/75	€ 720
Max. Load	L	1305	3305	3805	W
Inverter/charger		Multi	Multi	Multi	
GridAssist needed				48/3000/35	€ 2.180
GridAssist not needed		24/2000/50	48/3000/35	48/5000/70	
Hub-1: cost of the major components		€ 11.330	€ 14.428	€ 16.786	
Hub-2 or -3					
PV inverter		2kW	2kW	2,8	€ 1.670 kW
Efficiency PV inverter + Inverter/charger	$\eta_c \cdot \eta_{pv} \cdot \eta_v$	90	90	90	%
Max. Charge current	$\eta_c \cdot \eta_{pv} \cdot \eta_v \cdot A_{wp}/N_v$	62	37	45	A
Max. Load	L	1305	3305	3805	W
Inverter/charger		Multi	Multi	Multi	
GridAssist not needed		24/3000/70	48/3000/35	48/5000/70	€ 2.907
Hub-2 or -3: cost of the major components		€ 13.214	€ 15.101	€ 18.463	

Table 10: The average home
100% OPzS battery and 100% PV

The column labeled Category 1+2+3 includes non movable loads (= appliances always connected to the same socket) which, in this example, consume on average 2050 Wh per day:

- washing machine with electric water heater
- clothes dryer with electric heater
- dish washer with electric water heater
- gas fired cooktop
- gas fired central heating and boiler

Note:

In order to reduce the number of battery cells and increase Ah per cell, a lower DC system voltage is sometimes preferred.

The above average home		Category 1	Category 1+2	Category 1+2+3	
OPzS battery		(base load)	(plus pluggable loads)	(the complete home)	
Electric energy consumption					
Summertime	S	18,96	20,88	27,98	kWh
Wintertime	W	23,10	25,02	32,12	kWh
Annual	$E_y = 365 \cdot (S+W)/2$	7487	8170	10698	kWh
OPzS battery with sufficient storage capacity to store 100% of the daily summertime electric energy consumption					
Energy storage capacity	$S/(0,50 \cdot 0,94)$	40,34	44,43	59,53	kWh
Nominal voltage		48	48	48	V
Ah storage capacity	Esc/Nv	840	926	1240	Ah
Cost	312 €/kW	€ 12.586	€ 13.861	€ 18.574	
Solar array with sufficient output to supply 100% of the load during a sunny summer day					
Required daily Hub output	S* 1	18,96	20,88	27,98	kWh/day
Required daily PV output	$RdHo/0,75$	25,28	27,84	37,31	kWh
Array Wp	$RdPVo/6$	4213	4640	6218	Wp
Cost	2,19 €/Wp	€ 9.227	€ 10.162	€ 13.617	
Hub-1					
Efficiency solar charge controller + DC cables	$\eta_m \cdot \eta_w$	96	96	96	%
Max. Charge current	$\eta_m \cdot \eta_w \cdot A_{wp}/N_v$	84	93	124	A
Solar charge controller		MPPT 150/75	2*MPPT 150/75	2*MPPT 150/75	€ 1.440
		€ 720	€ 1.440	€ 1.440	
Max. Load	L	2560	4560	10560	W
Inverter/charger		Multi	Multi	Multi	
GridAssist needed			48/3000/35	48/5000/70	€ 2.180
GridAssist not needed		48/3000/35	48/5000/70	48/10000/140	€ 2.907
Hub-1: cost of the major components			€ 24.713	€ 27.642	€ 36.538
Hub-2 or -3					
PV inverter		5 kW	5 kW	8 kW	€ 2.554
Efficiency PV inverter + Inverter/charger	$\eta_c \cdot \eta_{pv} \cdot \eta_v$	90	90	90	%
Max. Charge current	$\eta_c \cdot \eta_{pv} \cdot \eta_v \cdot A_{wp}/N_v$	70	77	103	A
Max. Load	L	2560	4560	10560	W
Inverter/charger		Multi	Multi	Multi	
GridAssist not needed		48/5000/70	48/8000/110	48/10000/140	€ 2.907
Hub-2 or -3: cost of the major components			€ 27.274	€ 31.324	€ 41.424

Table 11: The above average home
100% Li-ion battery and 100% PV

The column labeled Category 1+2+3 includes non movable loads (= appliances always connected to the same socket) which, in this example, consume on average 7100 Wh per day:

- washing machine with electric water heater
- clothes dryer with electric heater
- dish washer with electric water heater
- electric induction cooktop
- gas fired central heating and boiler

Note:

In order to reduce the number of battery cells and increase Ah per cell, a lower DC system voltage is sometimes preferred.

Two person energy conscious household			Category 1+2		Category 1+2+3		
Li-ion battery	100%	7,62 kW	€ 9.395	69%	8,09 kW	€ 9.969	70%
PV array	100%	1.124 Wp	€ 2.461	18%	1.192 Wp	€ 2.611	18%
Solar charge controller		MPPT 70/50	€ 260	2%	MPPT 70/50	€ 260	2%
Inverter/charger		24/2000/50	€ 1.454	11%	24/2000/50	€ 1.454	10%
Hub-1: cost of the major components			€ 13.570	100%	€ 14.294	100%	
PV inverter		1,5 kW	€ 1.149	8%	1,5 kW	€ 1.149	8%
Inverter/charger		24/3000/70	€ 2.180	16%	24/3000/70	€ 2.180	15%
Hub-2 or -3: cost of the major components			€ 15.185	112%	€ 15.909	111%	
Li-ion battery	30%	2,29 kW	€ 2.819	40%	2,43 kW	€ 2.991	41%
PV array	100%	1.124 Wp	€ 2.461	35%	1.192 Wp	€ 2.611	36%
Solar charge controller		MPPT 70/50	€ 260	4%	MPPT 70/50	€ 260	4%
Inverter/charger		24/2000/50	€ 1.454	21%	24/2000/50	€ 1.454	20%
Hub-1: cost of the major components			€ 6.993	100%	€ 7.316	100%	
PV inverter		1,5 kW	€ 1.149	16%	1,5 kW	€ 1.149	16%
Inverter/charger		24/3000/70	€ 2.180	31%	24/3000/70	€ 2.180	30%
Hub-2 or -3: cost of the major components			€ 8.608	123%	€ 8.931	122%	
Li-ion battery	60%	4,57 kW	€ 5.637	42%	4,85 kW	€ 5.981	42%
PV array	200%	2.247 Wp	€ 4.921	37%	2.384 Wp	€ 5.222	37%
Solar charge controller		MPPT 150/70	€ 720	5%	MPPT 150/70	€ 720	5%
Inverter/charger		48/3000/35	€ 2.180	16%	48/3000/35	€ 2.180	15%
Hub-1: cost of the major components			€ 13.458	100%	€ 14.103	100%	
PV inverter		2,8 kW	€ 1.670	12%	2,8 kW	€ 1.670	12%
Inverter/charger		48/3000/35	€ 2.180	16%	48/3000/35	€ 2.180	15%
Hub-2 or -3: cost of the major components			€ 14.408	107%	€ 15.053	107%	
Li-ion battery	100%	7,62 kW	€ 9.395	48%	8,09 kW	€ 9.969	48%
PV array	300%	3.371 Wp	€ 7.382	38%	3.576 Wp	€ 7.832	38%
Solar charge controller		MPPT 150/70	€ 720	4%	MPPT 150/70	€ 720	3%
Inverter/charger		48/3000/35	€ 2.180	11%	48/3000/35	€ 2.180	11%
Hub-1: cost of the major components			€ 19.677	100%	€ 20.701	100%	
PV inverter		4 kW	€ 2.241	11%	4 kW	€ 2.241	11%
Inverter/charger		48/5000/70	€ 2.907	15%	48/5000/70	€ 2.907	14%
Hub-2 or -3: cost of the major components			€ 21.925	111%	€ 22.949	111%	
OPzS battery	100%	12,19 kW	€ 3.804	25%	12,94 kW	€ 4.036	26%
PV array	300%	3.820 Wp	€ 8.366	56%	4.053 Wp	€ 8.877	56%
Solar charge controller		MPPT 150/70	€ 720	5%	MPPT 150/70	€ 720	5%
Inverter/charger		48/3000/35	€ 2.180	14%	48/3000/35	€ 2.180	14%
Hub-1: cost of the major components			€ 15.070	100%	€ 15.813	100%	
PV inverter		4 kW	€ 2.241	15%	4 kW	€ 2.241	14%
Inverter/charger		48/5000/70	€ 2.907	19%	48/5000/70	€ 2.907	18%
Hub-2 or -3: cost of the major components			€ 17.318	115%	€ 18.061	114%	

Table 12a
Concentrated version
of table 6

Table 12b
Li-ion battery optimized
for self consumption
(see section 10.1)

Table 12c
Li-ion battery optimized
for self consumption
with 200% PV array

Table 12d
Li-ion battery optimized
for self consumption
with 300% PV array

Table 12e
OPzS battery optimized
for self consumption
with 300% PV array

Table 12 The two person energy conscious household

Average home			Category 1+2			Category 1+2+3		
Li-ion battery	100%	13,32 kW	€ 16.429	70%	16,05 kW	€ 19.790	71%	
PV array	100%	1.965 Wp	€ 4.303	18%	2.367 Wp	€ 5.183	19%	
Solar charge controller		MPPT 150/70	€ 720	3%	MPPT 150/70	€ 720	3%	
Inverter/charger		48/3000/35	€ 2.180	9%	48/3000/35	€ 2.180	8%	
Hub-1: cost of the major components			€ 23.632	100%		€ 27.873	100%	
PV inverter		2 kW	€ 1.393	6%	2,8 kW	€ 1.670	6%	
Inverter/charger		48/3000/35	€ 2.180	9%	48/5000/70	€ 2.907	10%	
Hub-2 or -3: cost of the major components			€ 24.305	103%		€ 29.550	106%	
Li-ion battery	30%	4,00 kW	€ 4.929	41%	4,82 kW	€ 5.937	42%	
PV array	100%	1.965 Wp	€ 4.303	35%	2.367 Wp	€ 5.183	37%	
Solar charge controller		MPPT 150/70	€ 720	6%	MPPT 150/70	€ 720	5%	
Inverter/charger		48/3000/35	€ 2.180	18%	48/3000/35	€ 2.180	16%	
Hub-1: cost of the major components			€ 12.131	100%		€ 14.020	100%	
PV inverter		2 kW	€ 1.393	11%	2,8 kW	€ 1.670	12%	
Inverter/charger		48/3000/35	€ 2.180	18%	48/5000/70	€ 2.907	21%	
Hub-2 or -3: cost of the major components			€ 12.804	106%		€ 15.697	112%	
Li-ion battery	60%	7,99 kW	€ 9.857	43%	9,63 kW	€ 11.874	45%	
PV array	200%	3.929 Wp	€ 8.605	38%	4.733 Wp	€ 10.366	39%	
Solar charge controller		2*MPPT 150/70	€ 1.440	6%	2*MPPT 150/70	€ 1.440	5%	
Inverter/charger		48/5000/70	€ 2.907	13%	48/5000/70	€ 2.907	11%	
Hub-1: cost of the major components			€ 22.810	100%		€ 26.587	100%	
PV inverter		4 kW	€ 1.670	7%	5 kW	€ 2.554	10%	
Inverter/charger		48/5000/70	€ 2.907	13%	48/5000/70	€ 2.907	11%	
Hub-2 or -3: cost of the major components			€ 23.040	101%		€ 27.701	104%	
Li-ion battery	100%	13,32 kW	€ 16.429	46%	16,05 kW	€ 19.790	48%	
PV array	300%	5.894 Wp	€ 12.908	36%	7.100 Wp	€ 15.549	37%	
Solar charge controller		2*MPPT 150/70	€ 1.440	4%	2*MPPT 150/70	€ 1.440	3%	
Inverter/charger		48/8000/110	€ 4.748	13%	48/8000/110	€ 4.748	11%	
Hub-1: cost of the major components			€ 35.525	100%		€ 41.527	100%	
PV inverter		6 kW	€ 2.800	8%	8 kW	€ 4.000	10%	
Inverter/charger		48/8000/110	€ 4.748	13%	48/8000/110	€ 4.748	11%	
Hub-2 or -3: cost of the major components			€ 36.885	104%		€ 44.087	106%	
OPzS battery	100%	21,32 kW	€ 6.652	24%	25,68 kW	€ 8.012	25%	
PV array	300%	6.680 Wp	€ 14.629	53%	8.047 Wp	€ 17.622	55%	
Solar charge controller		2*MPPT 150/70	€ 1.440	5%	2*MPPT 150/70	€ 1.440	5%	
Inverter/charger		48/8000/110	€ 4.748	17%	48/8000/110	€ 4.748	15%	
Hub-1: cost of the major components			€ 27.469	100%		€ 31.823	100%	
PV inverter		8 kW	€ 4.000	15%	10 kW	€ 5.000	16%	
Inverter/charger		48/8000/110	€ 4.748	17%	48/10000/140	€ 5.233	16%	
Hub-2 or -3: cost of the major components			€ 30.029	109%		€ 35.868	113%	

Table 13a
Concentrated version of table 7

Table 13b
Li-ion battery optimized for self consumption (see section 10.1)

Table 13c
Li-ion battery optimized for self consumption with 200% PV array

Table 13d
Li-ion battery optimized for self consumption with 300% PV array

Table 13e
OPzS battery optimized for self consumption with 300% PV array

Table 13 The average home

The above average home			Category 1+2		Category 1+2+3		
Li-ion battery	100%	27,77 kW	€ 34.235	73%	37,21 kW	€ 45.877	74%
PV array	100%	4.094 Wp	€ 8.966	19%	5.486 Wp	€ 12.015	19%
Solar charge controller		2*MPPT 150/70	€ 1.440	3%	2*MPPT 150/70	€ 1.440	2%
Inverter/charger		48/3000/35	€ 2.180	5%	48/5000/70	€ 2.907	5%
Hub-1: cost of the major components			€ 46.822	100%		€ 62.239	100%
PV inverter		5 kW	€ 2.554	5%	8 kW	€ 4.000	6%
Inverter/charger		48/8000/110	€ 4.748	10%	48/10000/140	€ 5.233	8%
Hub-2 or -3: cost of the major components			€ 50.504	108%		€ 67.125	108%
Li-ion battery	30%	8,33 kW	€ 10.271	44%	11,16 kW	€ 13.763	46%
PV array	100%	4.094 Wp	€ 8.966	38%	5.486 Wp	€ 12.015	40%
Solar charge controller		2*MPPT 150/70	€ 1.440	6%	2*MPPT 150/70	€ 1.440	5%
Inverter/charger		48/5000/70	€ 2.907	12%	48/5000/70	€ 2.907	10%
Hub-1: cost of the major components			€ 23.584	100%		€ 30.125	100%
PV inverter		5 kW	€ 2.554	11%	8 kW	€ 4.000	13%
Inverter/charger		48/8000/110	€ 4.748	20%	48/10000/140	€ 5.233	17%
Hub-2 or -3: cost of the major components			€ 26.539	113%		€ 35.011	116%
Li-ion battery	60%	16,66 kW	€ 20.541	45%	22,32 kW	€ 27.526	47%
PV array	200%	8.188 Wp	€ 17.932	40%	10.973 Wp	€ 24.030	41%
Solar charge controller		3*MPPT 150/70	€ 2.160	5%	3*MPPT 150/70	€ 2.160	4%
Inverter/charger		48/8000/110	€ 4.748	10%	48/10000/140	€ 5.233	9%
Hub-1: cost of the major components			€ 45.381	100%		€ 58.949	100%
PV inverter		10 kW	€ 5.000	11%	12 kW	€ 6.000	10%
Inverter/charger		48/10000/140	€ 4.748	10%	48/10000/140	€ 5.233	9%
Hub-2 or -3: cost of the major components			€ 48.221	106%		€ 62.789	107%
Li-ion battery	100%	27,77 kW	€ 34.235	47%	37,21 kW	€ 45.877	49%
PV array	300%	12.282 Wp	€ 26.898	37%	16.459 Wp	€ 36.045	38%
Solar charge controller		4*MPPT 150/70	€ 2.880	4%	5*MPPT 150/70	€ 3.600	4%
Inverter/charger		3*48/5000/70	€ 8.721	12%	3*48/5000/70	€ 8.721	9%
Hub-1: cost of the major components			€ 72.735	100%		€ 94.243	100%
PV inverter		15 kW	€ 7.500	10%	20	€ 10.000	11%
Inverter/charger		3*48/5000/70	€ 8.721	12%	3*48/8000/110	€ 14.244	15%
Hub-2 or -3: cost of the major components			€ 77.355	106%		€ 106.166	113%
OPzS battery	100%	44,43 kW	€ 13.861	25%	59,53 kW	€ 18.574	26%
PV array	300%	13.920 Wp	€ 30.485	54%	18.653 Wp	€ 40.851	57%
Solar charge controller		4*MPPT 150/70	€ 2.880	5%	5*MPPT 150/70	€ 3.600	5%
Inverter/charger		3*48/5000/70	€ 8.721	16%	3*48/5000/70	€ 8.721	12%
Hub-1: cost of the major components			€ 55.947	100%		€ 71.746	100%
PV inverter		15 kW	€ 7.500	13%	20	€ 10.000	14%
Inverter/charger		3*48/5000/70	€ 8.721	16%	3*48/8000/110	€ 14.244	20%
Hub-2 or -3: cost of the major components			€ 60.567	108%		€ 83.669	117%

Table 14a
Concentrated version of table 8

Table 14b
Li-ion battery optimized for self consumption (see section 10.1)

Table 14c
Li-ion battery optimized for self consumption with 200% PV array

Table 14d
Li-ion battery optimized for self consumption with 300% PV array

Table 14e
OPzS battery optimized for self consumption with 300% PV array

Table 14 The above average home